

SGC Technologies, Inc.

PRODUCT SPECIFICATION FOR INFORMATION

PRODUCT NAME: SBP-3R3 TYPE

PART NO: SBP-3R3-1244BP10B

Parameter	Spec
Center frequency(Fo)	1244.62 MHz
Pole	3
Bandwidth(BW)	Fo ± 5 MHz
Insertion Loss in BW	3.0 dB max.
Ripple in BW	0.5 dB max.
Return Loss in BW	15 dB Min.
Attenuation	-
In/Out Impedance	50 ohm

NOTE:

EQUIPMENT used :HP 8753D

DIMENSION:

TOP VIEW

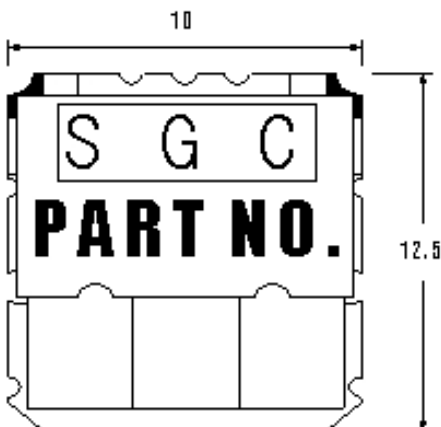

SIDE VIEW

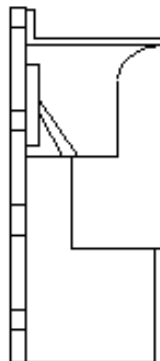

BOTTOM VIEW

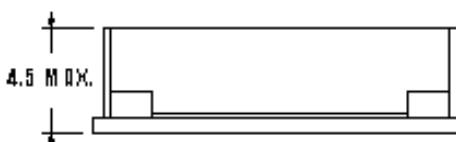
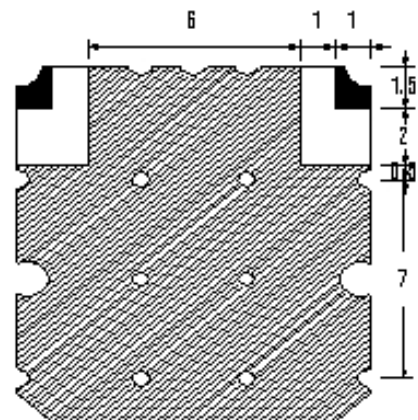

TOLERANCE UNLESS OTHERWISE SPECIFIED : ±0.3
DIMENSIONS : mm

 GROUND
 I/O PORT

Diagram A

Part Number : SBP-3R3-1244BP10B

