

# SGC Technologies, Inc.

## PRODUCT SPECIFICATION FOR INFORMATION

**PRODUCT NAME: SBP-3R3 TYPE**

**PART NO: SBP-3R3-1900BP10B**

Center frequency	1900 MHz
Pole	3
Bandwidth(BW)	Fo ±5 MHz
Insertion Loss	2.0 dB max
VSWR in BW	1.5 max
Ripple in BW	0.5 dB max
Attenuation	15dB at 1960MHz
In/Out Impedance	50 ohm

**NOTE:**

EQUIPMENT used :HP 8753E

**DIMENSION:**

**TOP VIEW**

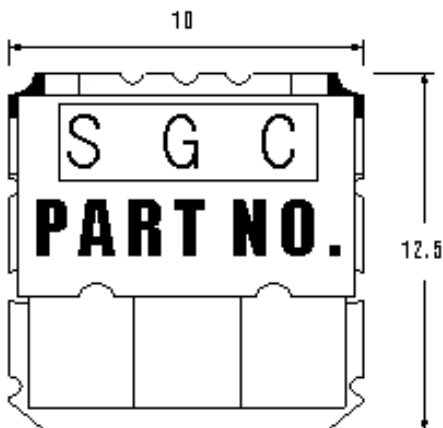

**SIDE VIEW**

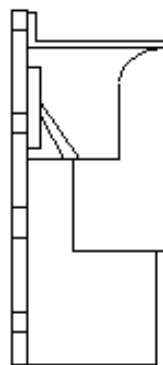

**BOTTOM VIEW**

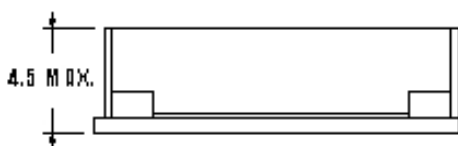
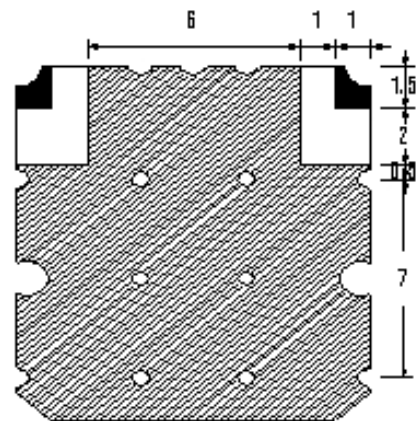

**TOLERANCE UNLESS OTHERWISE SPECIFIED : ±0.3**  
**DIMENSIONS : mm**

 **GROUND**  
 **I/O PORT**

# SBP-3R3-1900BP10B

