

SGC Technologies, Inc.

PRODUCT SPECIFICATION FOR INFORMATION

PRODUCT NAME: SBP-3R3 TYPE

PART NO: SBP-3R3-1950BP60A

Center frequency	1950MHz
Pole	3
Bandwidth(BW)	$F_o \pm 30\text{MHz}$
Insertion Loss in BW	3.0dB max
V.S.W.R	1.4 max
Ripple in BW	0.3dB max
Attenuation	25dBc MIN at 2110MHz 25dBc MIN at 2170MHz
In/Out Impedance	50 ohm

NOTE:

EQUIPMENT used :HP 8753E

DIMENSION:

TOP VIEW

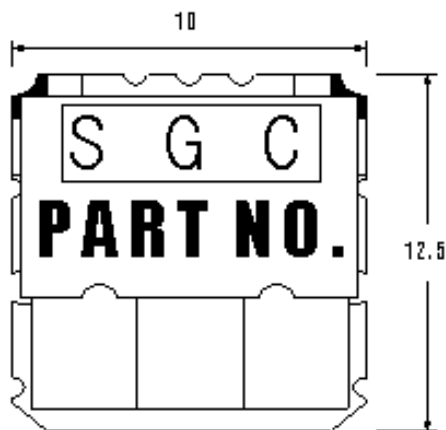

SIDE VIEW

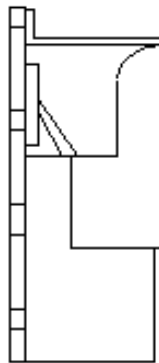

BOTTOM VIEW

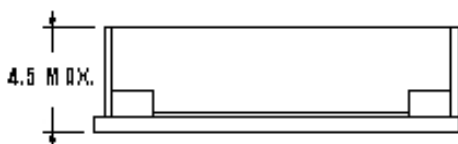
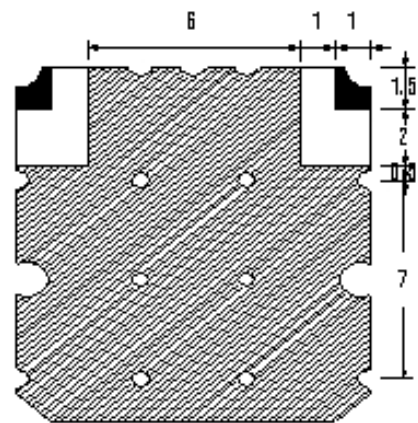

TOLERANCE UNLESS OTHERWISE SPECIFIED : ±0.3
DIMENSIONS : mm

 **GROUND**
 **I/O PORT**

SBP-3R3-1950BP60A

