

SGC Technologies, Inc.

PRODUCT SPECIFICATION FOR INFORMATION

PRODUCT NAME: SBP-3R3 TYPE

PART NO: SBP-3R3-2544BP42H

Center frequency	2544 MHz
Pole	3
Bandwidth(BW)	Fo \pm 21MHz
Insertion Loss	2.5 dB max
VSWR in BW	1.7 max
Ripple in BW	0.8 dB max
Attenuation	7dB at \pm 53MHz
In/Out Impedance	50 ohm

NOTE:

EQUIPMENT used :HP 8753E

DIMENSION:

TOP VIEW

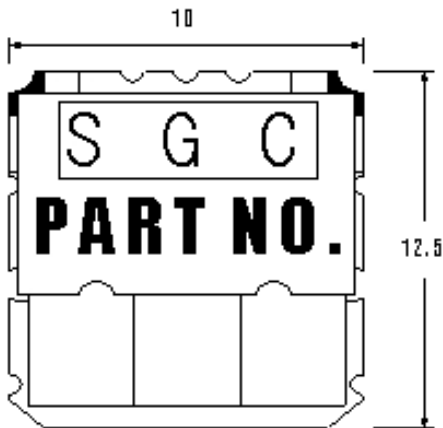

SIDE VIEW

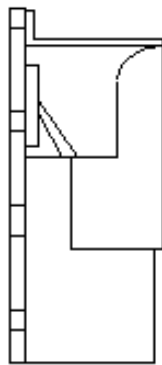

BOTTOM VIEW

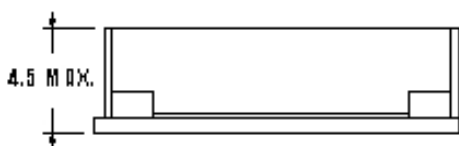
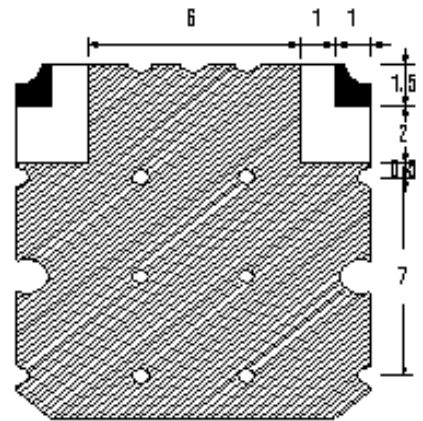

TOLERANCE UNLESS OTHERWISE SPECIFIED : \pm 0.3
DIMENSIONS : mm

 **GROUND**
 **I/O PORT**

SBP-3R3-2544BP42H

