

# SGC Technologies, Inc.

## PRODUCT SPECIFICATION FOR INFORMATION

**PRODUCT NAME: SBP-3R3 TYPE**

**PART NO: SBP-3R3-942.5BP35M**

Center frequency	942.5MHz
Pole	3
Bandwidth(BW)	Fo ±17.5MHz
Insertion Loss	3.0 dB max
Return Loss	15dB min
Ripple in BW	1.0 dB max
Attenuation	Fo ±70 MHz at 20dB min
In/Out Impedance	50 ohm

**NOTE:**

**EQUIPMENT used :HP 8753E**

**DIMENSION:**

**TOP VIEW**

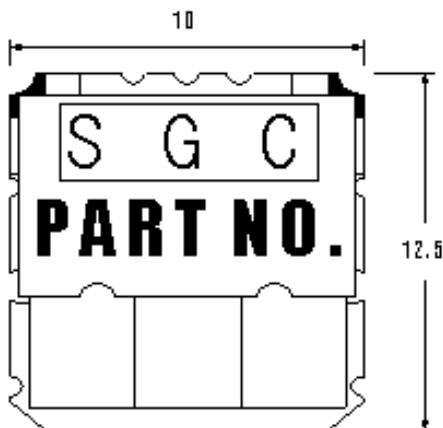

**SIDE VIEW**

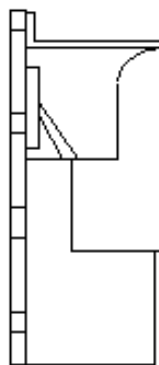

**BOTTOM VIEW**

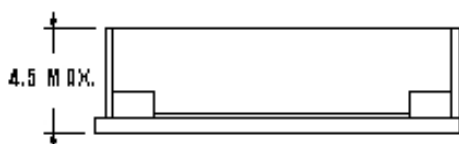
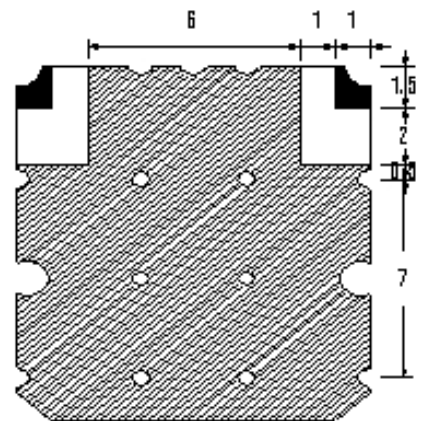

**TOLERANCE UNLESS OTHERWISE SPECIFIED : ±0.3  
DIMENSIONS : mm**

 **GROUND**  
 **I/O PORT**

# SBP-3R3-942.5BP35M

