

SGC Technology, Inc.

PRODUCT SPECIFICATION FOR INFORMATION

PRODUCT NAME : BPF(SMD) TYPE

PART NO : SBP-4R12-233-240-247-254BP7M

ITEM	CH1	CH2	CH3	CH4
Center Frequency	233.5MHz	240.5MHz	247.5MHz	254.5MHz
Band Width	Fo ±3.5MHz			
Insertion Loss	1.0dB max			
Ripple	0.5 dB max			
V.S.W.R	1.4 max			
Attenuation	Freq.		ATT.	
	Fo ± 20MHz		30dB min	
Impedance	50Ω			
Pole	4POLE			
Power	50W			
Operating Temp	-40°C to +50°C			

NOTE : EQUIPMENT used HP 8753E

DIMENSION

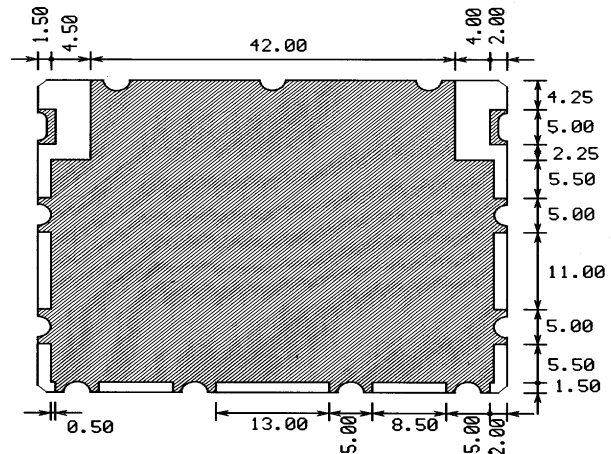
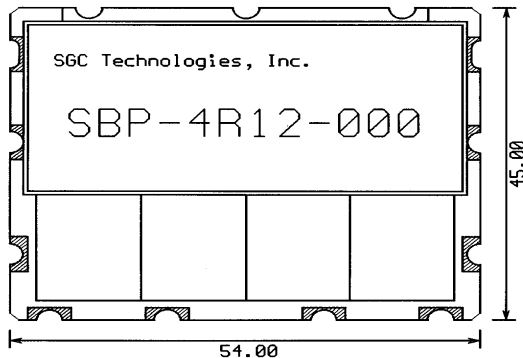

Tolerance Unless Specified : +/- 0.3
Unit : mm

Graph 1

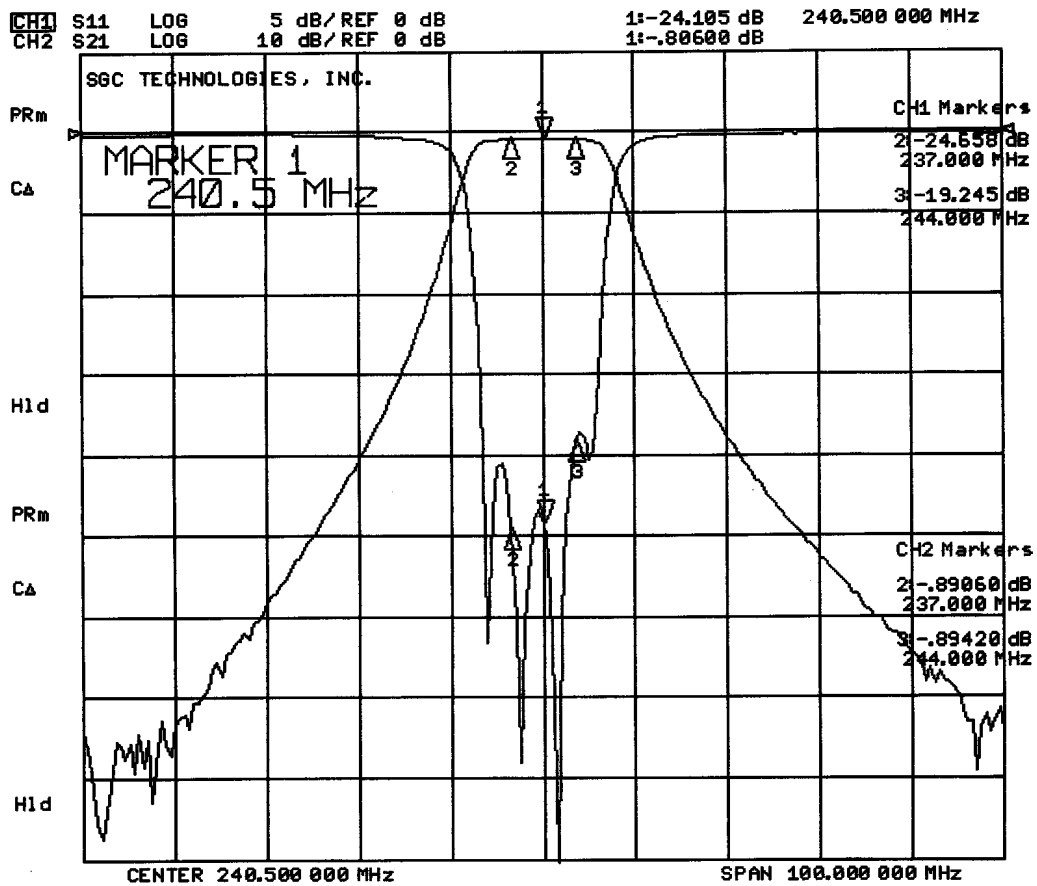
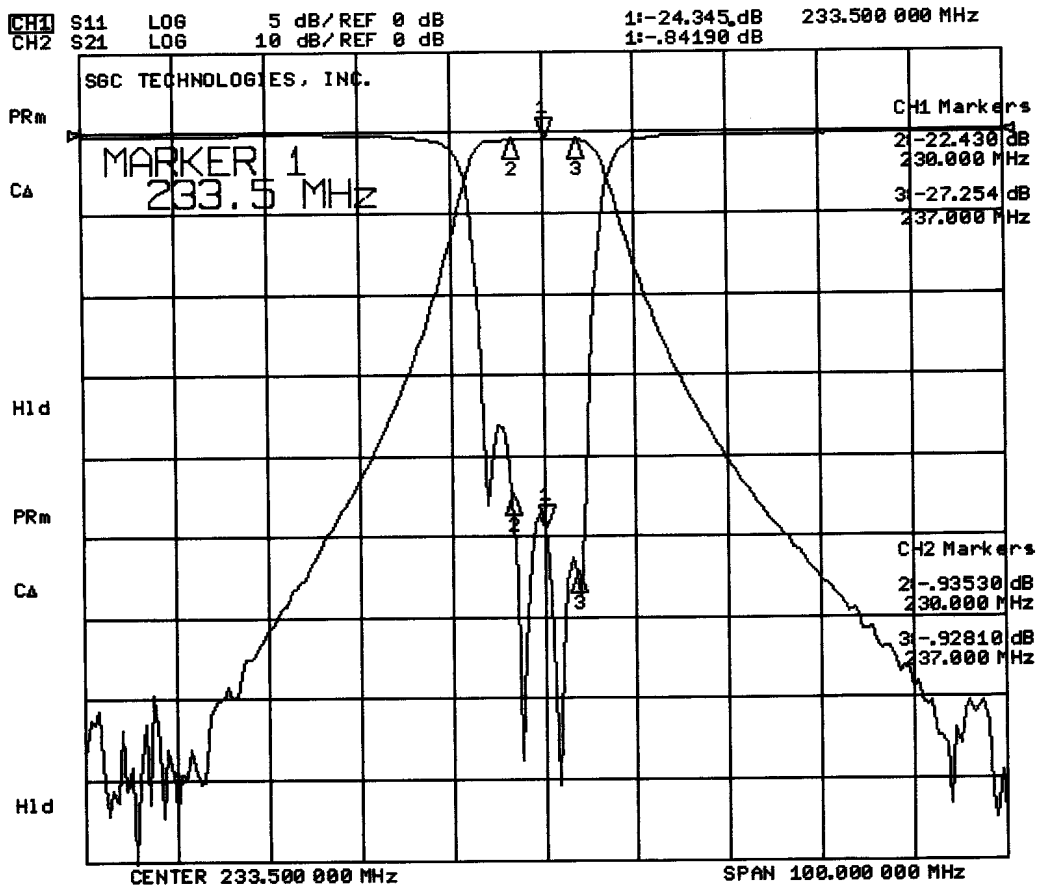

Graph 2

