

SGC Technologies, Inc.

PRODUCT SPECIFICATION FOR INFORMATION

PRODUCT NAME: SDPX-8R8-TYPE

PART NO: SDPX-1950-8R8-2140BP60M

Center frequency	1950 MHz	2140 MHz
Pole	4	4
Bandwidth(BW)	Fo ±30 MHz	Fo ±30 MHz
Insertion Loss	2.5dB max	2.5 dB max
VSWR in BW	1.5 max	1.5 max
Ripple in BW	0.5 dB max	0.5 dB max
Attenuation	50dB min at 2110MHz-2170 MHz	55dB min at 1930MHz-1980 MHz
In/Out Impedance	50 ohm	50 ohm

NOTE:

EQUIPMENT used :HP 8753E

DIMENSION:

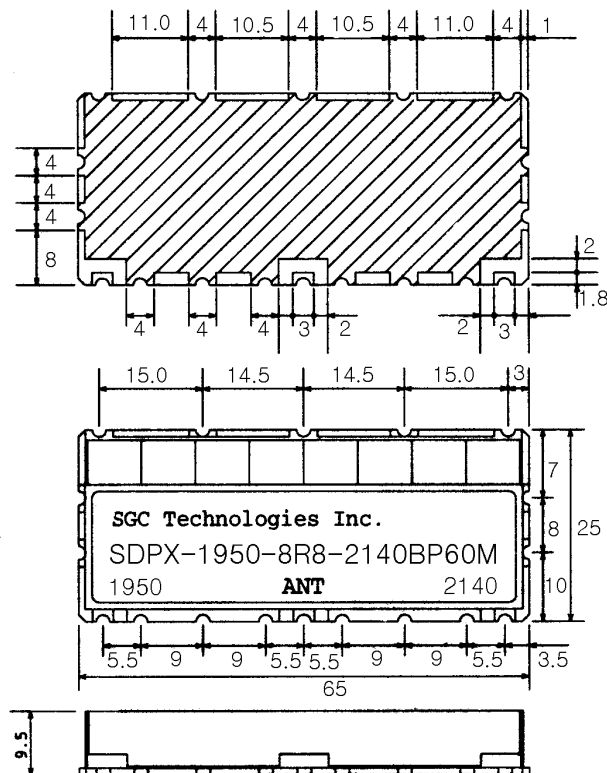

Unit : mm

SDPX-1950-8R8-2140BP60M

CH1 S₂₂ log MAG 5 dB/ REF 0 dB 3: -20.282 dB
 CH2 S₂₁ log MAG 10 dB/ REF 0 dB 3: -1.3846 dB

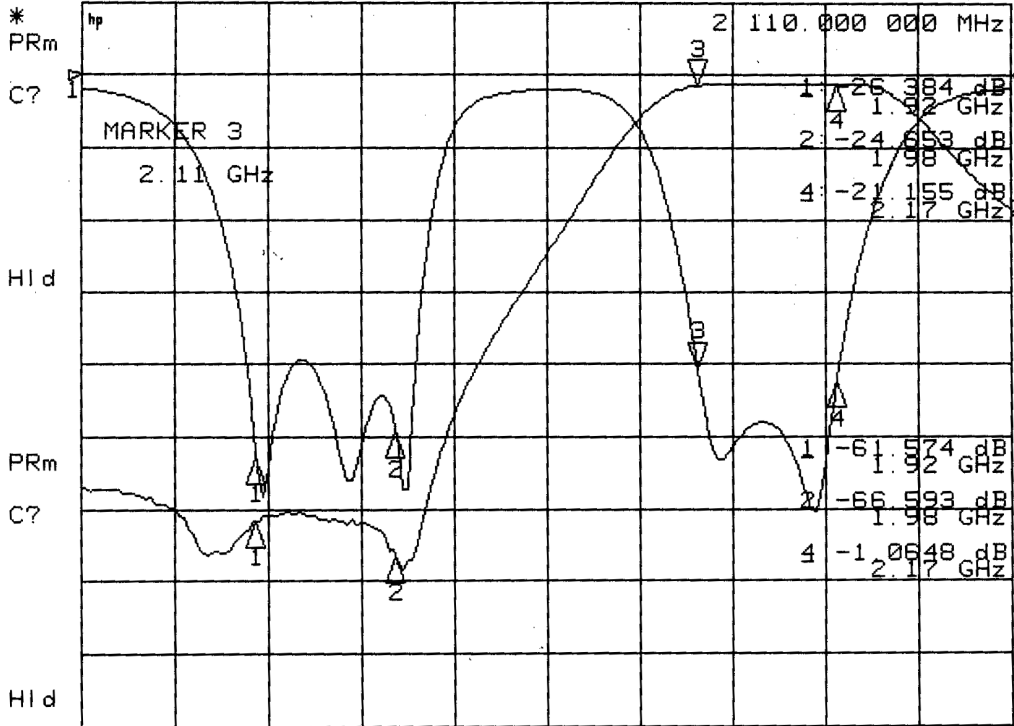

CENTER 2 045.000 000 MHz SPAN 400.000 000 MHz

CH1 S₁₁ log MAG 5 dB/ REF 0 dB 2: -23.864 dB
 CH2 S₂₁ log MAG 10 dB/ REF 0 dB 2: -1.4371 dB

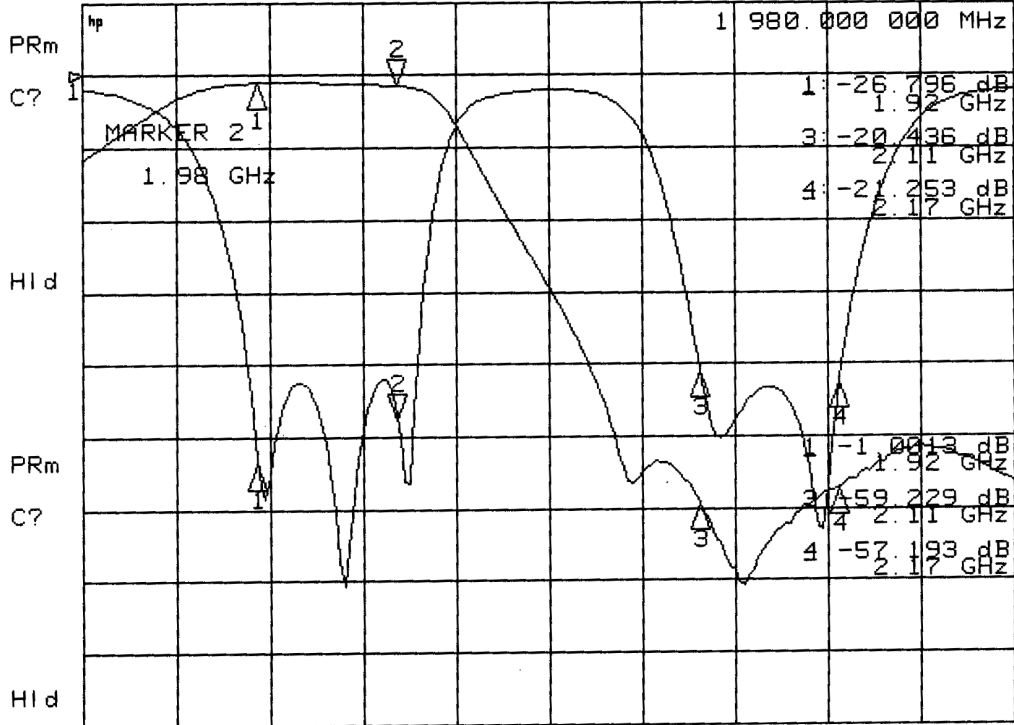

CENTER 2 045.000 000 MHz SPAN 400.000 000 MHz

SDPX-1950-8R8-2140BP60M

