

# SGC Technologies, Inc.

## PRODUCT SPECIFICATION FOR INFORMATION

PRODUCT NAME: SB-2R-SM TYPE

PART NO: SB-2R-SM-1227BP30C

Center frequency	1227MHz
Pole	2
Bandwidth(BW)	Fo ±15 MHz
Insertion Loss	1.8 dB max
V.S.W.R in BW	1.5 max
Ripple in BW	1.0 dB max
Attenuation	Fo ±100MHz at 20dB min
In/Out Impedance	50 ohm

NOTE: EQUIPMENT used :HP 8753E

### DIMENSION:

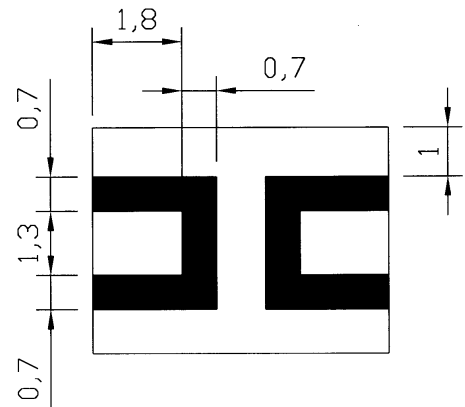
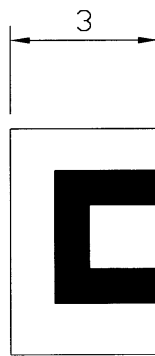
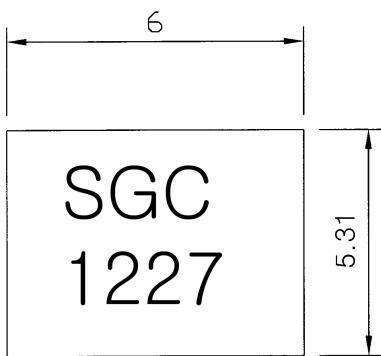
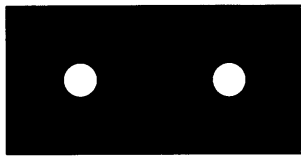

Unit:mm  
Tolerance:±0.3

# SB-2R-SM-1227BP30C

