

# SGC Technologies, Inc.

Wireless and Internet Communication

## PRODUCT SPECIFICATION FOR INFORMATION

PRODUCT NAME: SB-2R-SM TYPE

PART NO: SB-2R-SM-1300BP15M

Center frequency	1300MHz
Pole	2
Bandwidth(BW)	Fo $\pm$ 7.5 MHz
-1 dB Band Width	30~40 dB min
Insertion Loss	1.7 dB max
V.S.W.R in BW	1.7 max
Ripple in BW	0.5 dB max
Attenuation	+/-70 at 10dB
In/Out Impedance	50 ohm

NOTE: EQUIPMENT used :HP 8753E

### DIMENSION:

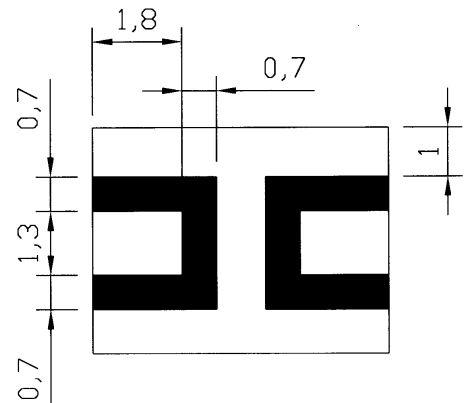
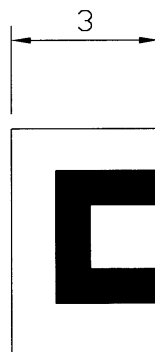
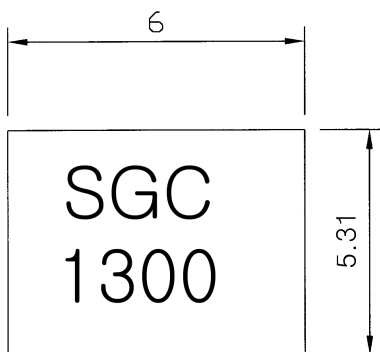

Unit:mm  
Tolerance:±0.3

# SB-2R-SM-1300BP15M

