

# SGC Technologies, Inc.

Wireless and Internet Communication

## PRODUCT SPECIFICATION FOR INFORMATION

PRODUCT NAME: SB-2R-SM TYPE

PART NO: SB-2R-SM-1575BP20M

Center frequency	1575.42MHz
Pole	2
Bandwidth(BW)	Fo ±10 MHz
Insertion Loss	2.5 dB max
V.S.W.R in BW	1.7 max
Ripple in BW	0.5 dB max
Attenuation	Fo ±100MHz at 20dB min
In/Out Impedance	50 ohm

NOTE: EQUIPMENT used :HP 8753E

### DIMENSION:

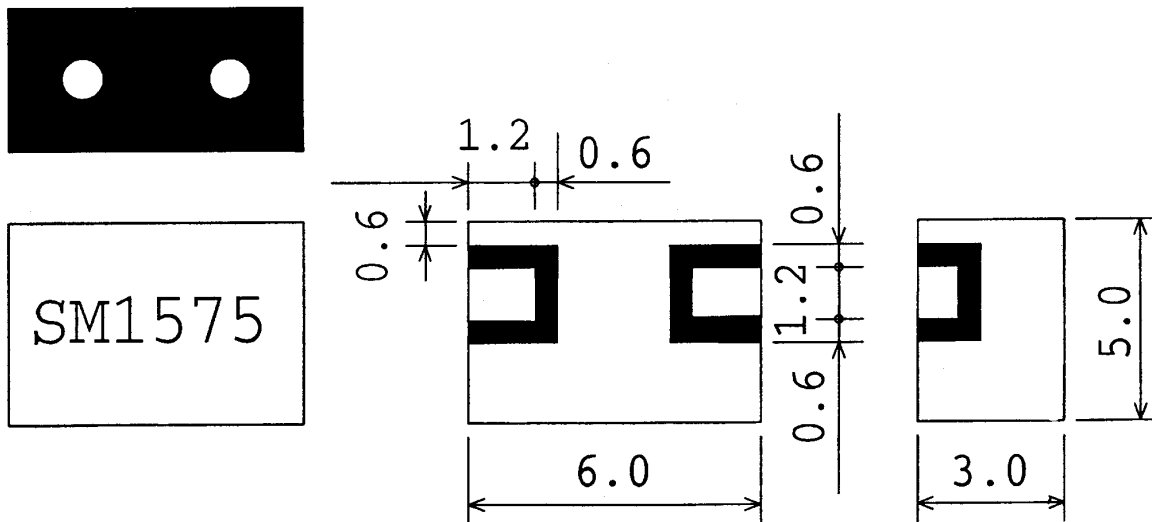

UNIT: mm

TOLERANCE: +/- 0.3