

SGC Technologies, Inc.

Wireless and Internet Communication

PRODUCT SPECIFICATION FOR INFORMATION

PRODUCT NAME: SB-2R-SM TYPE

PART NO: SB-2R-SM-881BP25M

Center frequency	881.5MHz
Pole	2
Band width(BW)	Fo ±12.5MHz
Insertion Loss	2.5 dB max
V.S.W.R.	2.0 max
Ripple	1.0 dB max
Attenuation	Fo-32.5MHz at 9dB min Fo+ 32.5MHz at 6.5dB min
In/Out Impedance	50 ohm

NOTE: EQUIPMENT used :HP 8753E

DIMENSION:

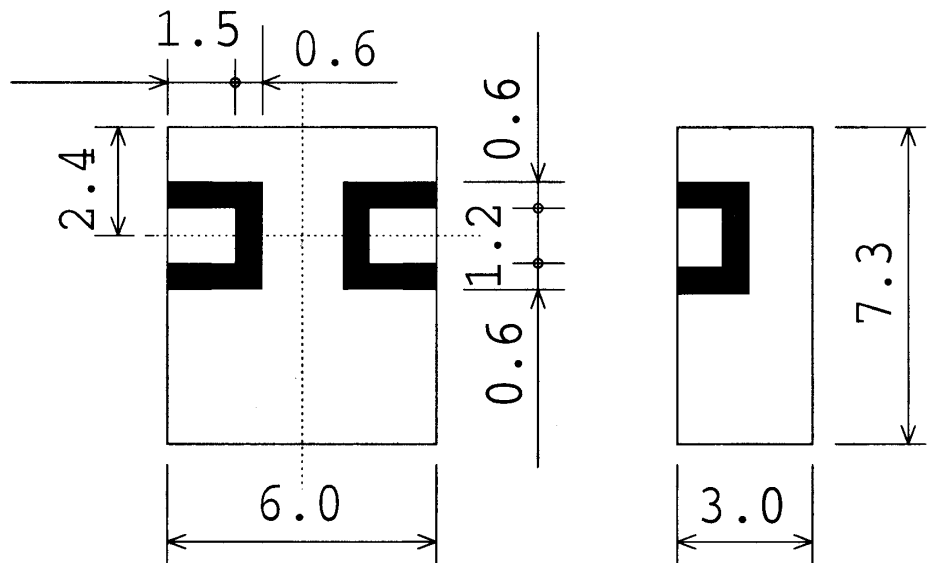
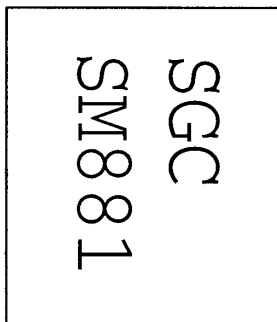

UNIT : mm

TOLERANCE : +/- 0.3

SB-2R-SM-881BP25M

