

SGC Technologies, Inc.

PRODUCT SPECIFICATION FOR INFORMATION

CUSTOMER :

PRODUCT NAME : LC BPF TYPE

PART NO : SLB-70-BP2MB

ITEM	SPEC.
Cutoff frequency	70 MHz
Bandwidth	2 MHz
Insertion loss	3.6 dB max
Ripple	1.0 dB max
V.S.W.R.	1.4 : 1
Attenuation	50 dB @ 40 MHz 50 dB @ 100 MHz
In/Out Impedance	50 ohm

NOTE : EQUIPMENT used HP 8753E

DIMENSION

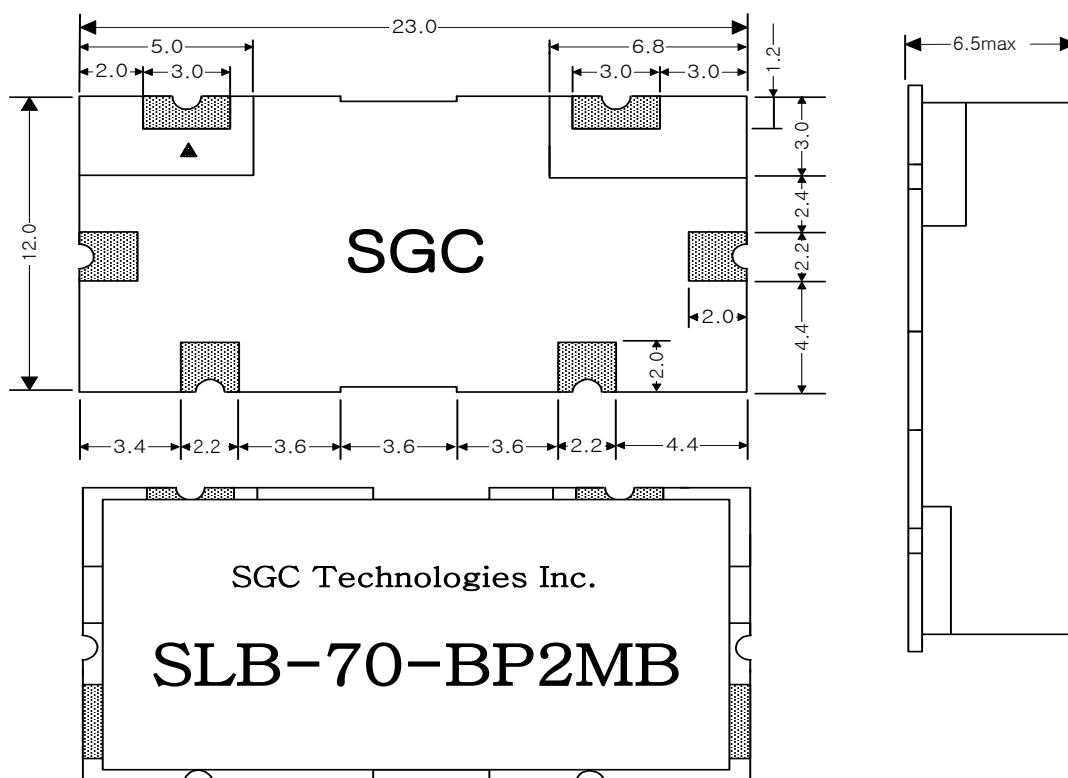

SLB-70-BP2MB

22 May 2003 12:12:40

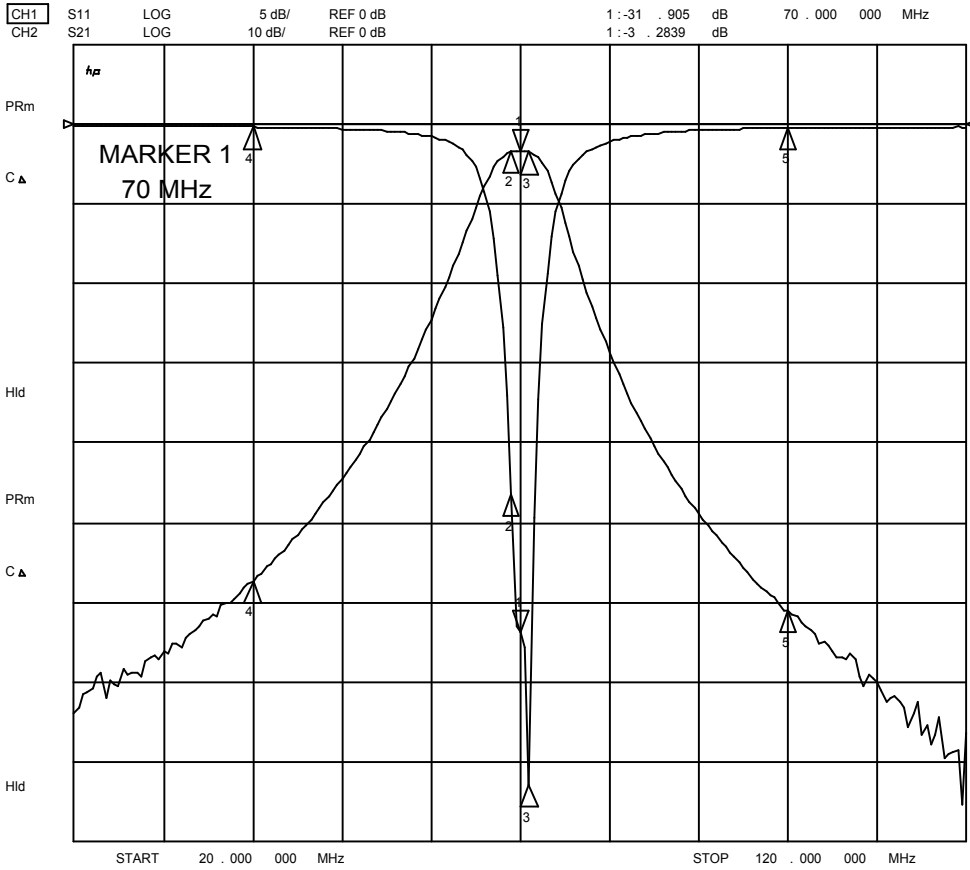

CH1 Markers

2	-23.237	dB	69.0000	MHz
3	-41.542	dB	71.0000	MHz
4	-17360	dB	40.0000	MHz
5	-23040	dB	100.000	MHz

CH2 Markers

2	-3.3863	dB	69.0000	MHz
3	-3.4818	dB	71.0000	MHz
4	-57.323	dB	40.0000	MHz
5	-61.129	dB	100.000	MHz

22 May 2003 12:12:55

CH1 S11 1 UFS 1: 49.994 Ω 2.5332 Ω 5.7596 nH 70.000 000 MHz

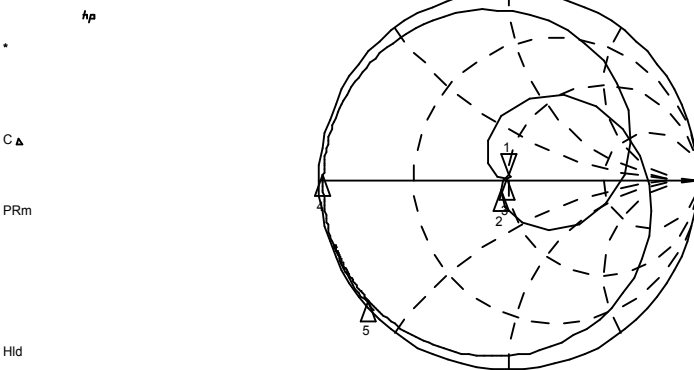

CH1 Markers

2	45.775	Ω	-5.0781	Ω	69.0000	MHz
3	49.375	Ω	0.5508	Ω	71.0000	MHz
4	499.91	mΩ	599.30	mΩ	40.0000	MHz
5	0.7539	Ω	-18.501	Ω	100.000	MHz

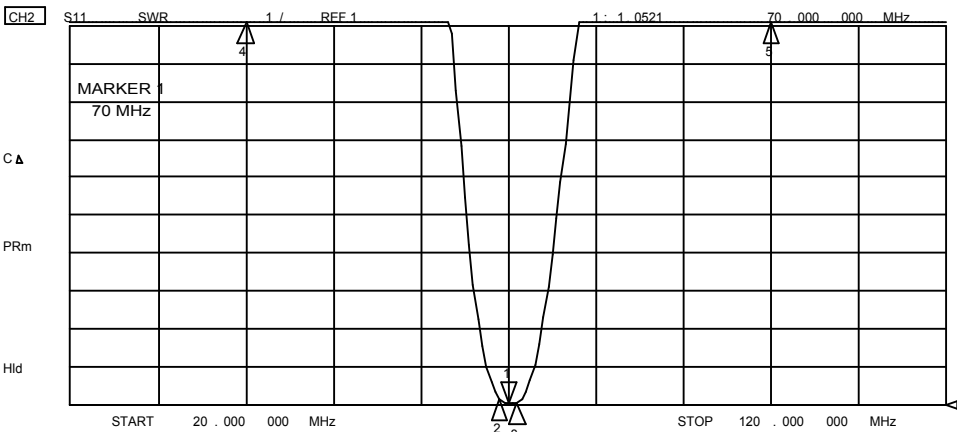

CH2 Markers

2	1.1479		69.0000	MHz
3	1.0168		71.0000	MHz
4	100.07		40.0000	MHz
5	75.383		100.000	MHz