

SGC Technologies, Inc.

PRODUCT SPECIFICATION FOR INFORMATION

CUSTOMER :

PRODUCT NAME : LC BPF TYPE

PART NO : SLB-70-BP3MD

ITEM	SPEC.
Cutoff frequency	70 MHz
Bandwidth	3 MHz
Insertion loss	3.2 dB max
Ripple	1.0 dB max
V.S.W.R.	1.4 : 1
Attenuation	40 dB @ 40 MHz 40 dB @ 100 MHz
In/Out Impedance	50 ohm

NOTE : EQUIPMENT used HP 8753E

DIMENSION

TOP VIEW

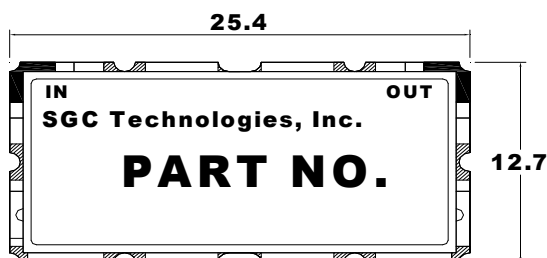

SIDE VIEW

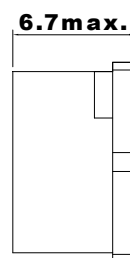

BOTTOM VIEW



TOLERANCE UNLESS
OTHERWISE SPECIFIED : ± 0.3
DIMENSIONS : mm

 GROUND
 I/O PORT

SLB-70-BP3MD

22 May 2003 12:13:37

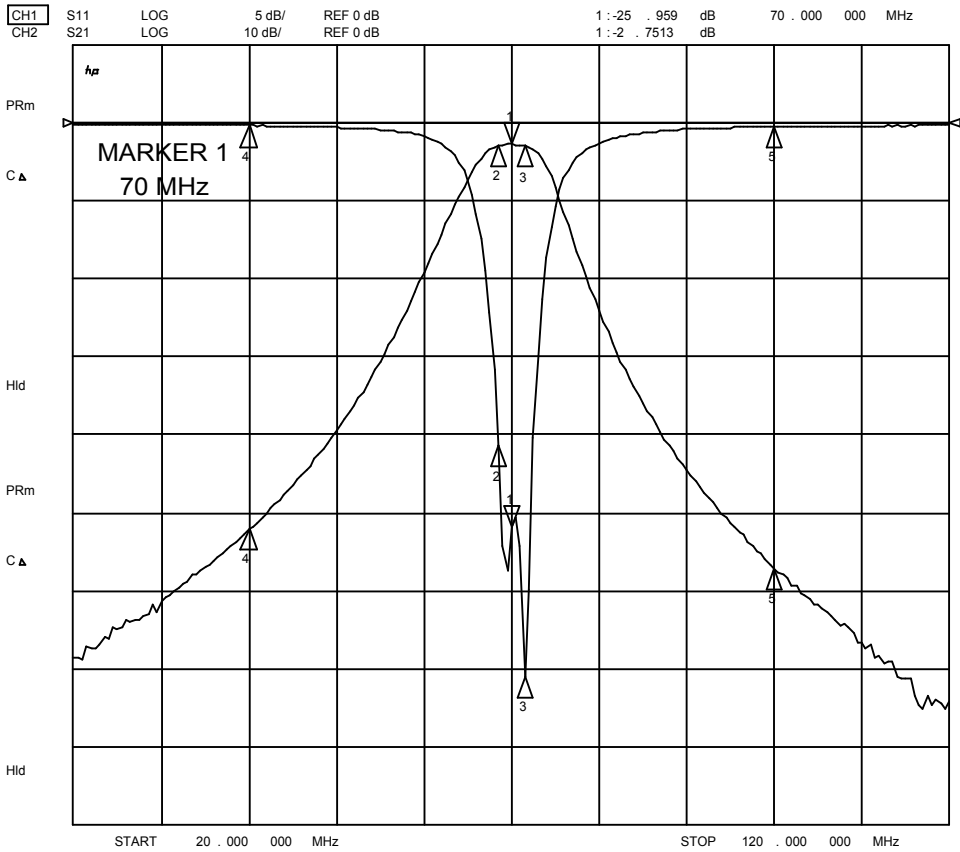

22 May 2003 12:13:47

CH1 S11 1 UFS 1: 48.902 Ω 4.8613 Ω 11.053 nH 70.000 000 MHz

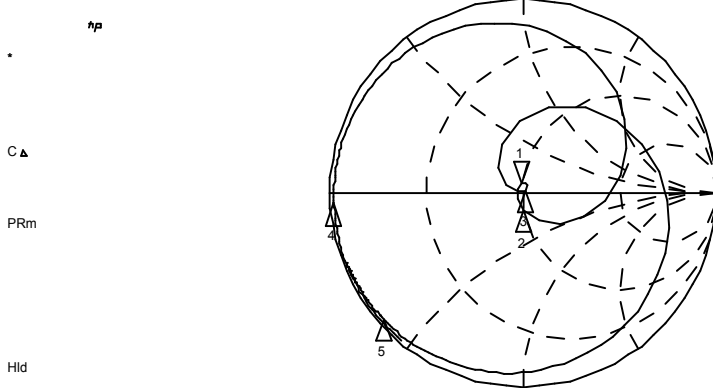

CH2 S11 SWR 1 / REF 1 1: 1.1060 70.000 000 MHz

