

SGC Technologies, Inc.

PRODUCT SPECIFICATION FOR INFORMATION

CUSTOMER :

PRODUCT NAME : HOUSING BPF TYPE

PART NO : SLB-434-BP4M(H)

ITEM	SPEC.
Cutoff frequency	434 MHz
Bandwidth	4 MHz
Insertion loss	4 dB max
Ripple	1 dB max
V.S.W.R.	1.5 : 1
Attenuation	-
In/Out Impedance	50 ohm

NOTE : EQUIPMENT used HP 8753E

DIMENSION

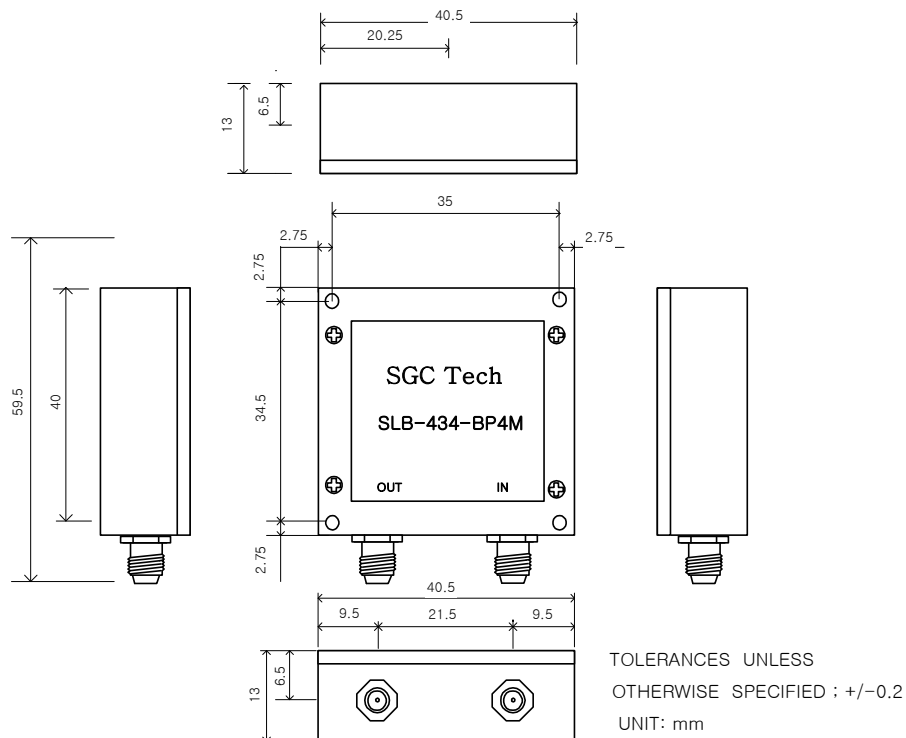

SLB-434-BP4M(H)

18 Dec 2003 20:43:00

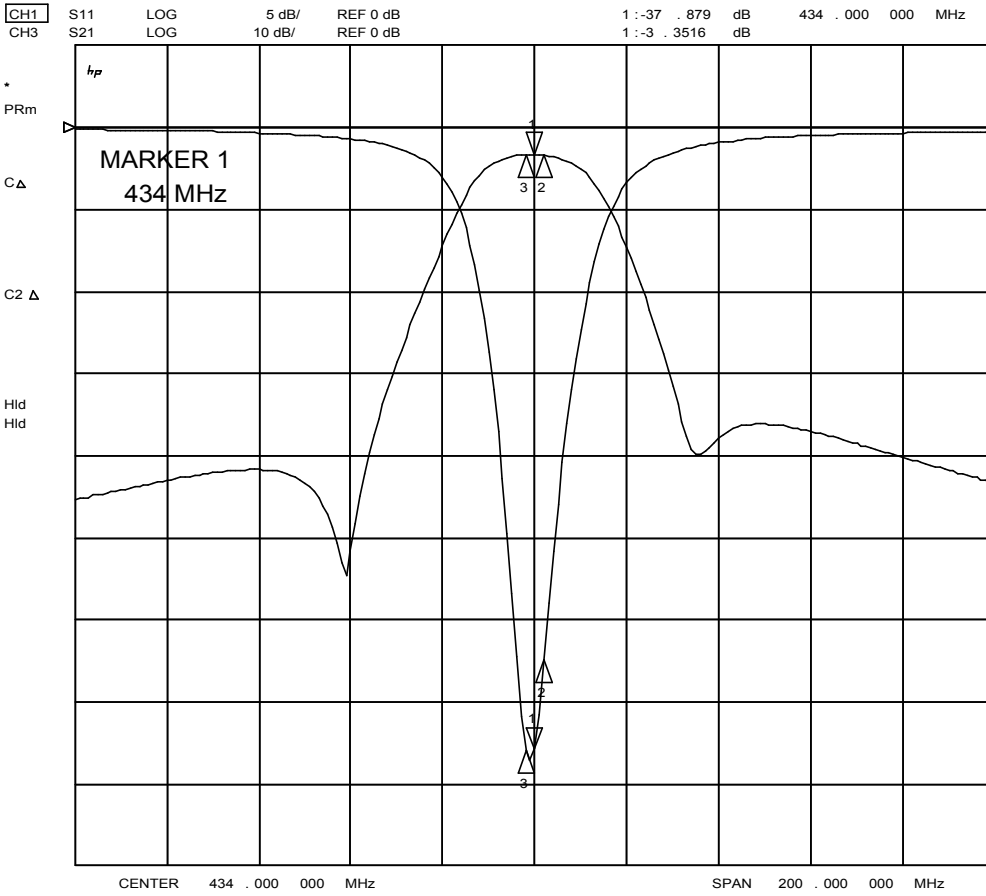

CH1 Markers

2: -32.455 dB
 436.000 MHz

3: -37.997 dB
 432.000 MHz

CH3 Markers

2: -3.4249 dB
 436.000 MHz

3: -3.3584 dB
 432.000 MHz

18 Dec 2003 20:42:40

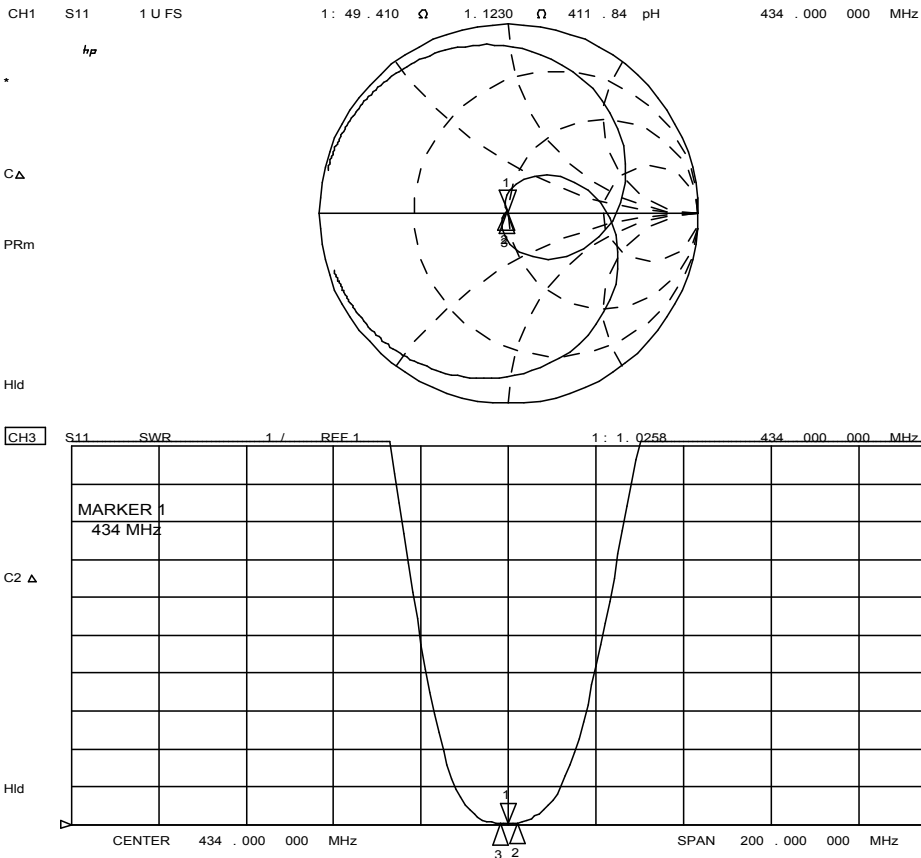

CH1 Markers

2: 48.682 Ω
 1.9473 Ω
 436.000 MHz

3: 49.098 Ω
 0.8652 Ω
 432.000 MHz

CH3 Markers

2: 1.0488
 436.000 MHz

3: 1.0255
 432.000 MHz

SLB-434-BP4M(H)

18 Dec 2003 20:43:30

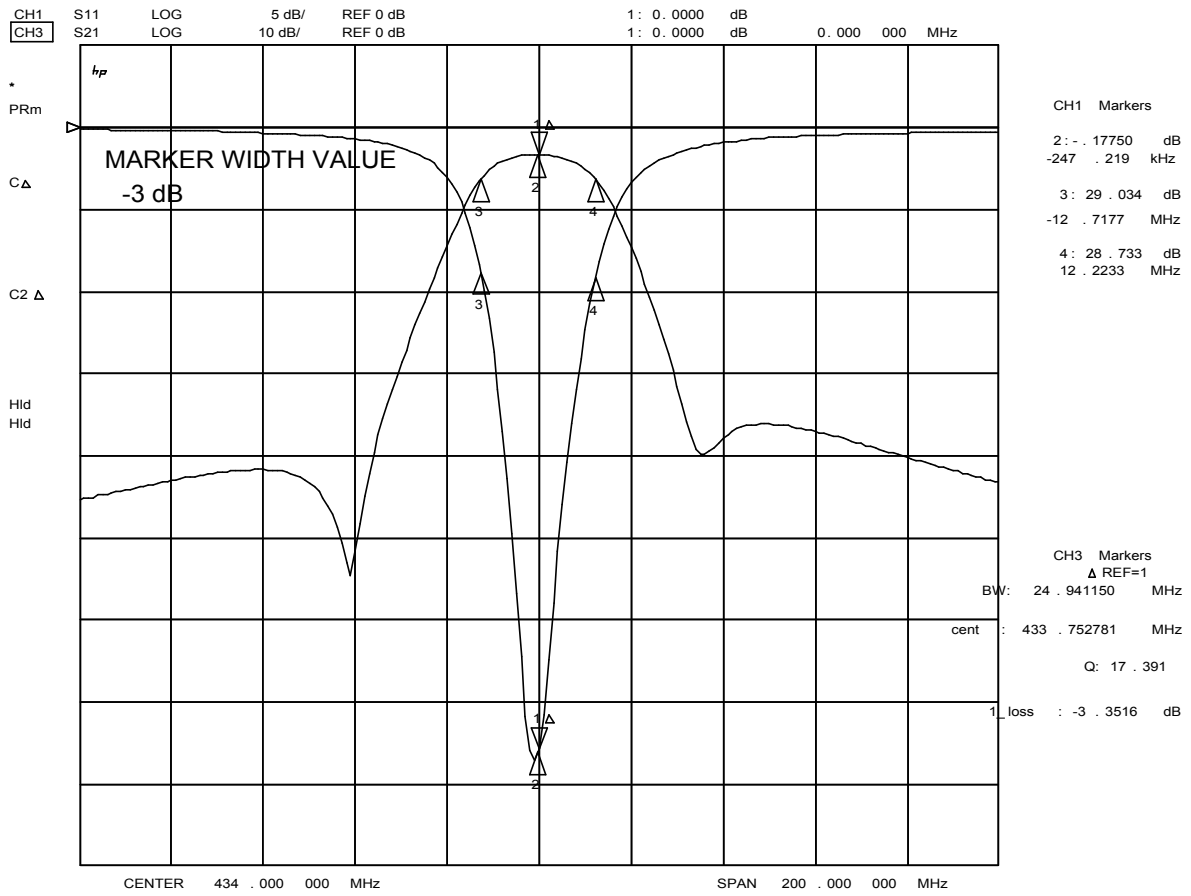

18 Dec 2003 20:43:54

