

SGC Technologies , Inc.

PRODUCT SPECIFICATION FOR INFORMATION

CUSTOMER :

PRODUCT NAME : DPX TYPE

PART NO : SLD-46LP-98BP20MLCM12

ITEM	SPEC.	
Center frequency	46.5MHz	98MHz
Bandwidth	Low pass (35.5~46.5MHz)	20MHz (88 MHz~108MHz)
Insertion loss	1.0dB max.	2.0dB max.
Ripple	0.5dB max.	1.0dB max.
V.S.W.R	1.4:1	1.4:1
Attenuation	50dB @ 88MHz	60dB @ 46MHz 50dB @ 204MHz

NOTE: EQUIPMENT used HP 8753E

DIMENSION:

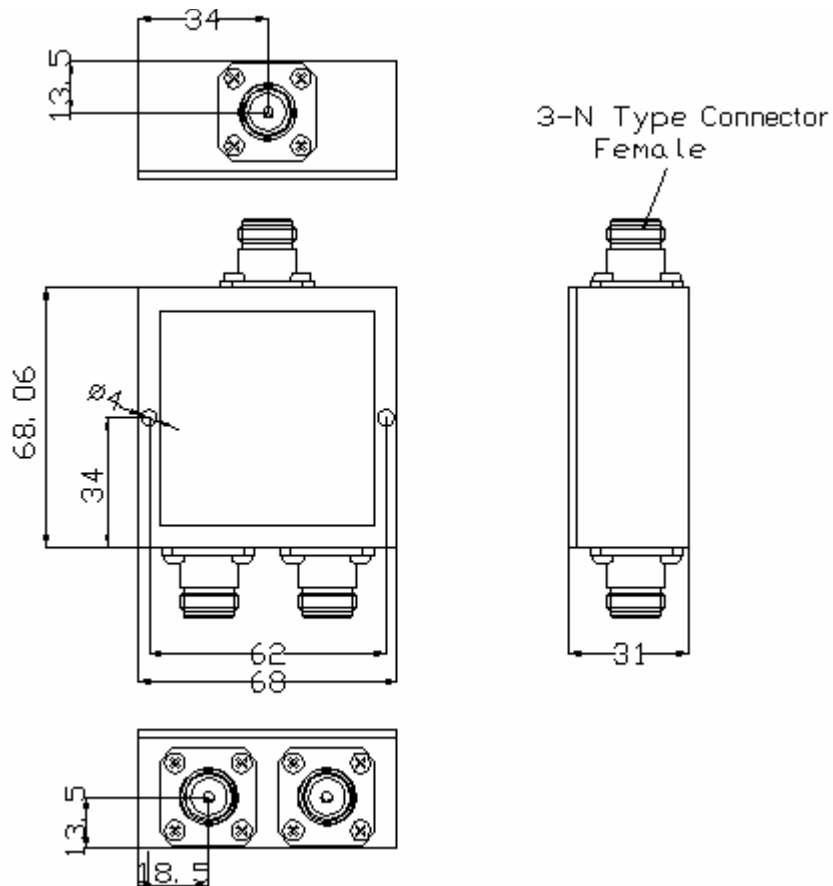

SLB-46LP-98BP20LCM12

26 Sep 2003 21:00:08

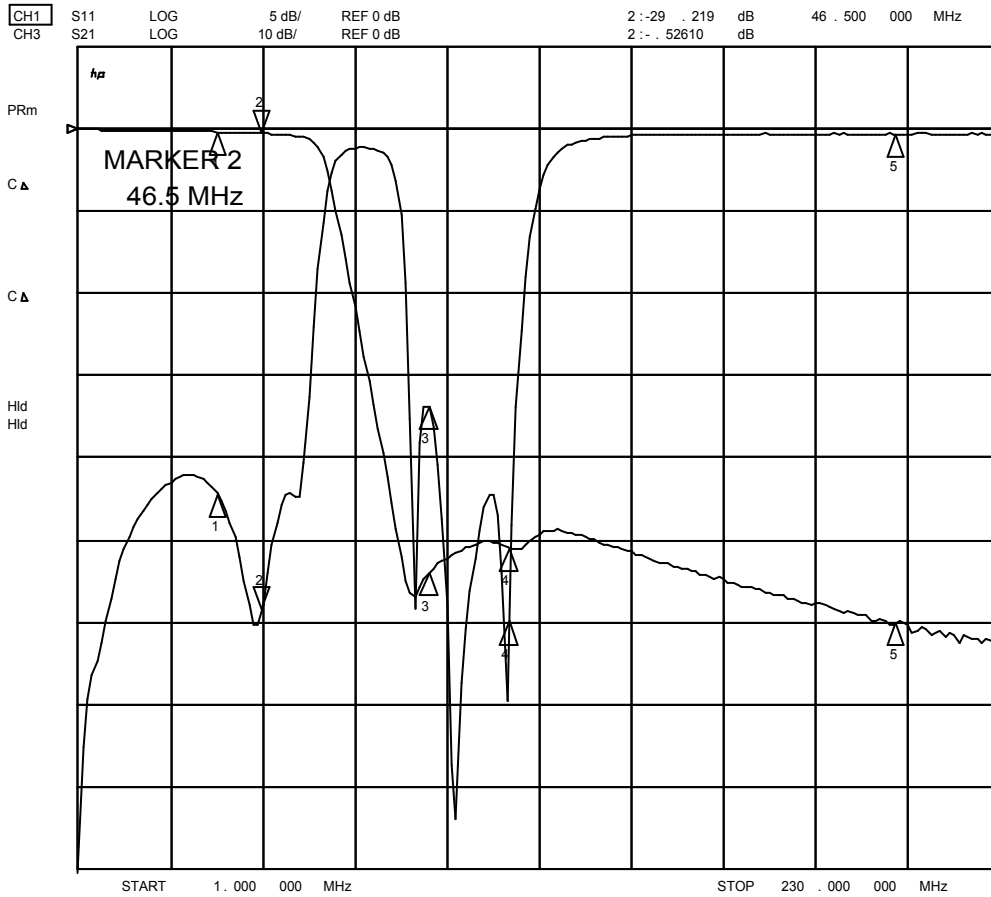

26 Sep 2003 20:37:11

