

SGC Technology , Inc.

PRODUCT SPECIFICATION FOR INFORMATION

CUSTOMER :

PRODUCT NAME : DPX TYPE

PART NO : SLD-315BP-433BP-10M

ITEM	SPEC.	
Center frequency	315MHz	433MHz
Bandwidth	10MHz	10MHz
Insertion loss	2.5dB max.	2.5dB max.
Ripple	1.0dB max.	1.0dB max.
V.S.W.R	1.4:1	1.4:1
Attenuation	45dB @ 438MHz	45dB @ 310MHz
In/Out Impedance	50 ohm	

NOTE: EQUIPMENT used HP 8753E

DIMENSION:

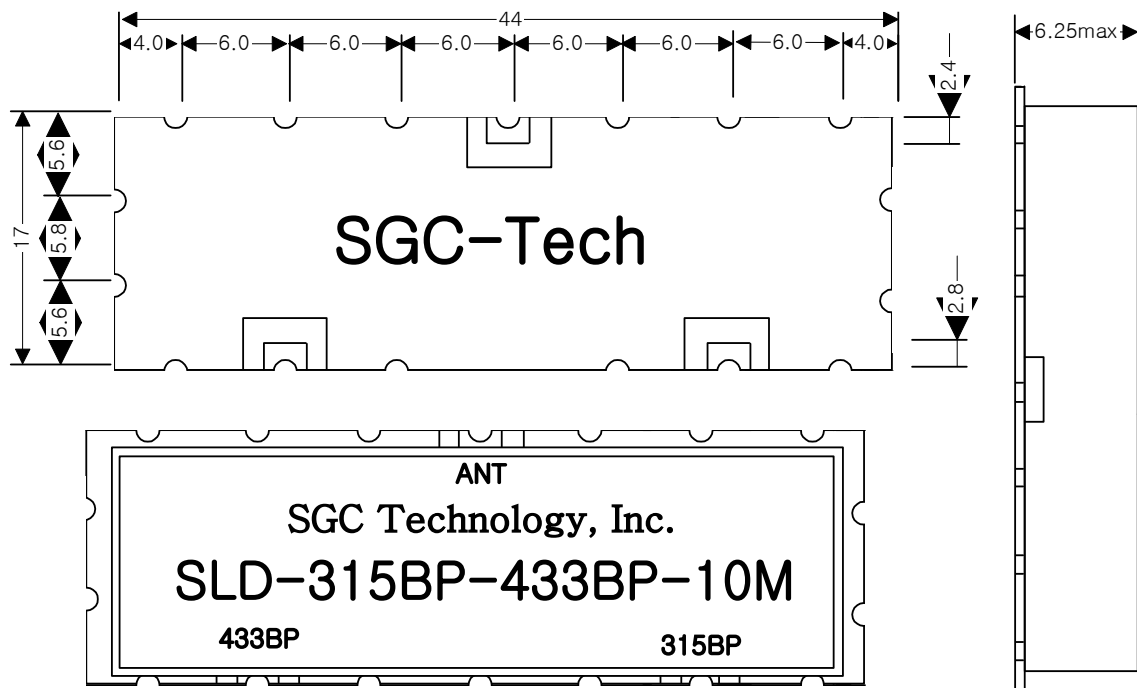

UNIT : mm

SLD-315BP-433BP-10M

14 Aug 2003 19:02:33

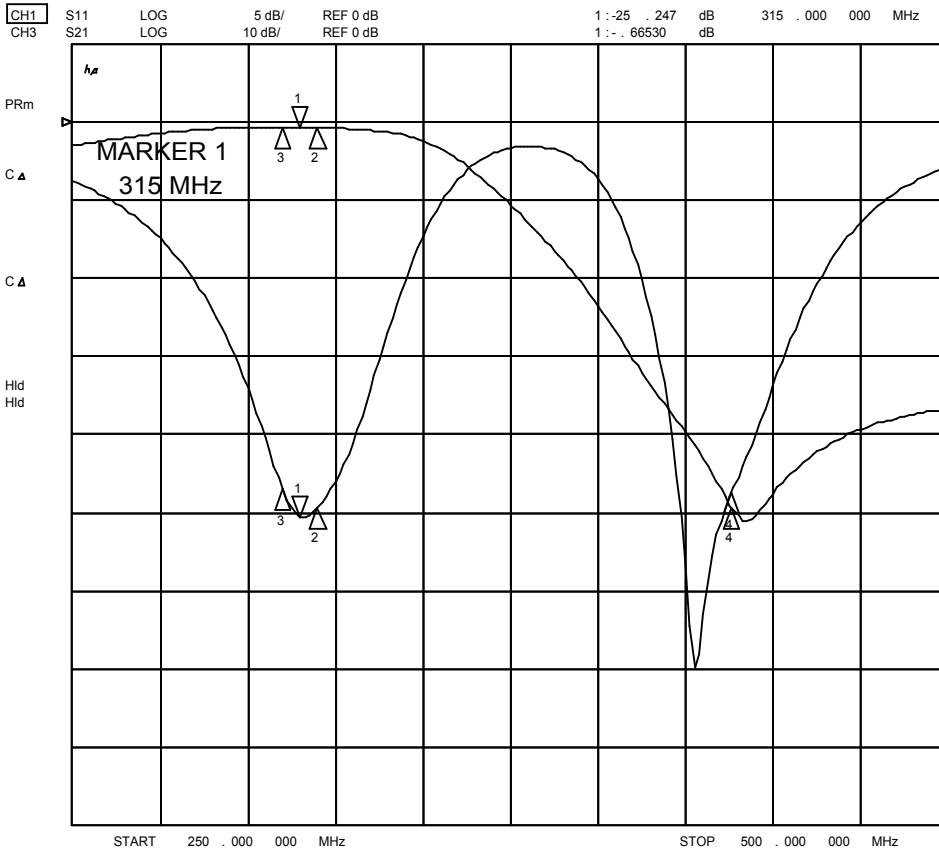

14 Aug 2003 19:01:12

