

Typical Performance

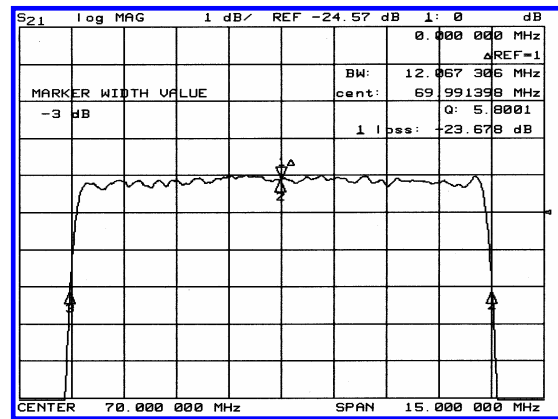
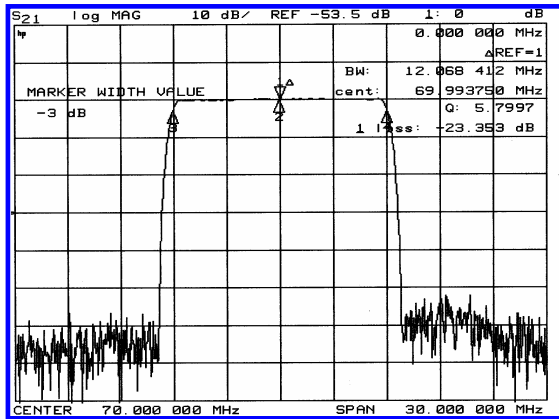

Specification

Parameter	Unit	Min.	Typ.	Max.
Center Frequency	Mhz	69.92	70.00	70.08
Insertion Loss	dB	-	23.5	25.0
3dB Bandwidth	Mhz	11.95	12.05	-
40dB Bandwidth	Mhz	-	13.45	13.60
Passband Ripple	dB	-	0.45	0.80
Group Delay Variation	nsec	-	80	150
Absolute Delay	µsec	-	2.35	-
Ultimate Attenuation	dB	50	55	-
Substrate Material	-	128-LiNbO ₃		

Package Dimension

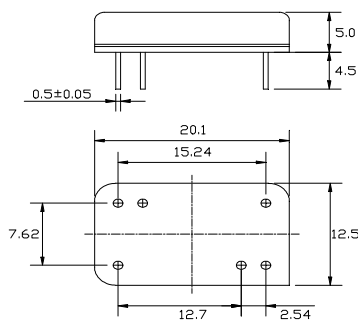

Matching Configuration

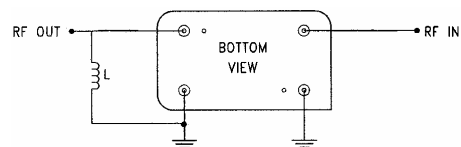

L = 330nH
Bottom View
Source / Load Impedance = 50Ω
Ambient Temperature = 25°C