

Typical Performance

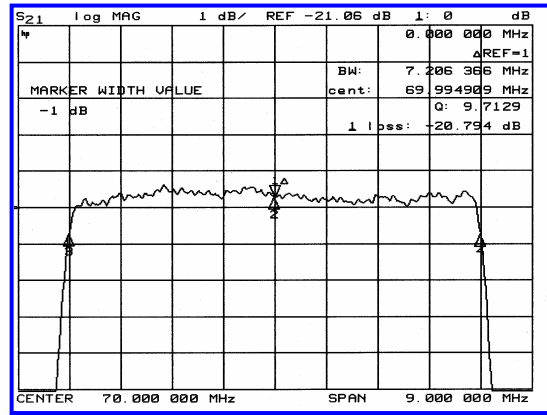
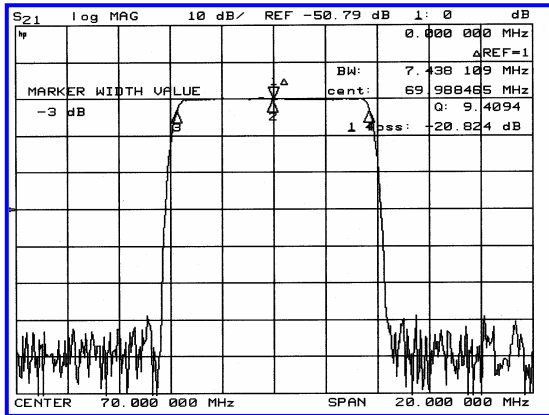

Specification

Parameter	Unit	Min.	Typ.	Max.
Center Frequency	Mhz	69.92	70.00	70.08
Insertion Loss	dB		21.00	22.50
3dB Bandwidth	Mhz	7.30	7.45	
50dB Bandwidth	Mhz		8.60	8.70
Passband Ripple	dB		0.55	1.00
Group Delay Variation	nsec		150	200
Absolute Delay	usec		3.25	
Ultimate Attenuation	dB	50	60	
Substrate Material	-		128-LiNbO ₃	

Package Dimension

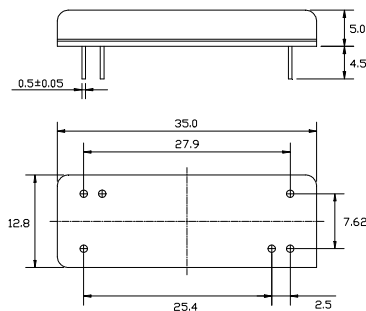

Matching Configuration

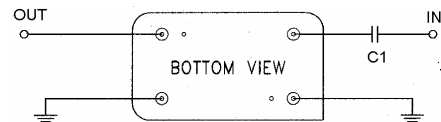

C1 = 180pF
 Source / Load Impedance = 50Ω
 Ambient Temperature = 25°C