

Typical Performance

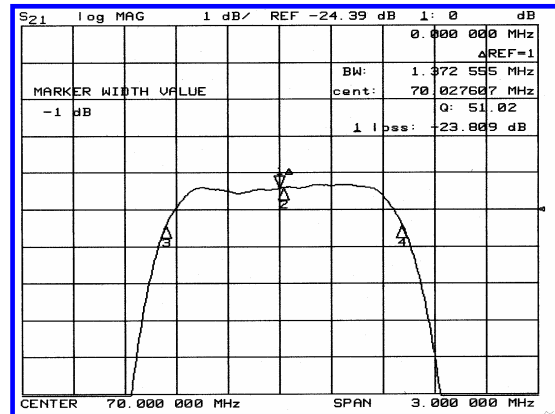
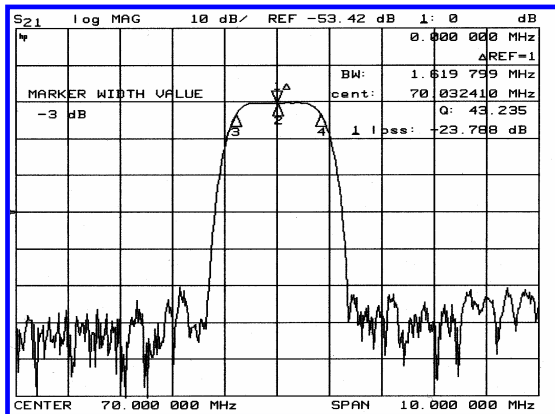

Specification

Parameter	Unit	Min.	Typ.	Max.
Center Frequency	Mhz	69.92	70.00	70.08
Insertion Loss	dB		23.50	25.00
3dB Bandwidth	Mhz	1.50	1.60	
40dB Bandwidth	Mhz		2.55	2.80
Passband Ripple	dB		0.35	0.70
Group Delay Variation	nsec		100	200
Absolute Delay	usec		2.85	
Ultimate Attenuation	dB	50	55	
Substrate Material	-		Quartz	

Package Dimension

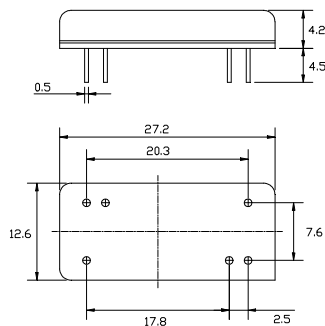

Matching Configuration

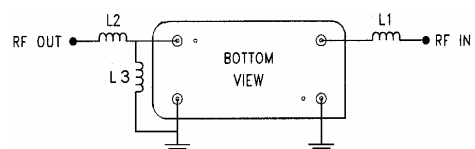

L1=L2=0.18uH , L3=0.22uH
Source / Load Impedance = 50Ω
Ambient Temperature = 25°C