

Typical Performance

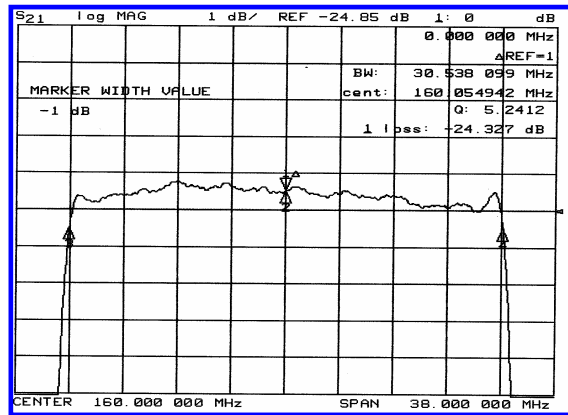
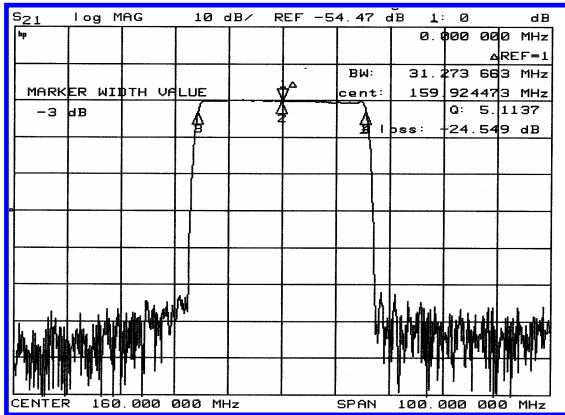

Specification

Parameter	Unit	Min.	Typ.	Max.
Center Frequency	Mhz	159.80	160.00	160.20
Insertion Loss	dB	-	24.50	26.00
1dB Bandwidth	Mhz	30.20	30.53	-
3dB Bandwidth	Mhz	31.00	31.27	-
40dB Bandwidth	Mhz	-	34.30	34.60
Passband Ripple	dB	-	0.75	1.00
Group Delay Variation	nsec	-	30	50
Absolute Delay	µsec	-	1.1	-
Ultimate Attenuation	dB	50	55	-
Substrate Material	-	128-LiNbO ₃		
Temperature Coefficient	ppm/°C	-72		

Package Dimension

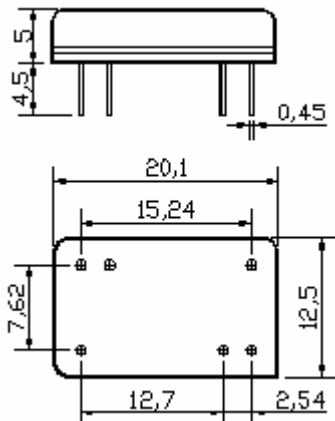

Matching Configuration

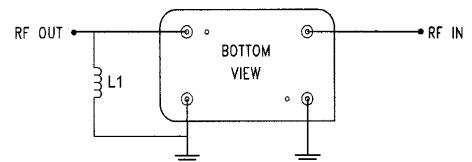

L1 = 220nH
Source / Load Impedance = 50Ω
Ambient Temperature = 25°C