

Typical Performance

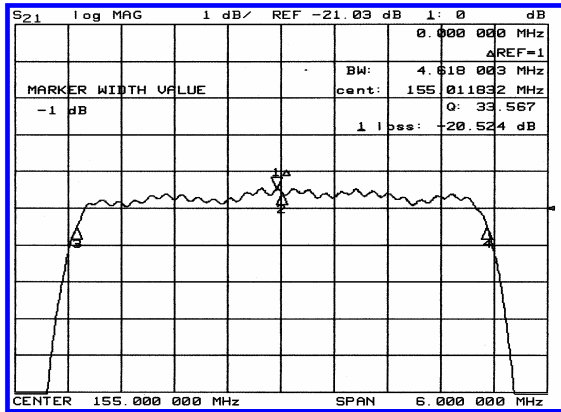
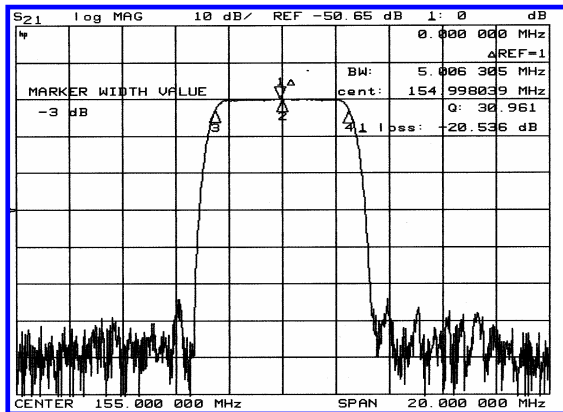

Specification

Parameter	Unit	Min.	Typ.	Max.
Center Frequency	Mhz	154.85	155.00	155.15
Insertion Loss	dB	-	20.5	22.0
1dB Bandwidth	Mhz	4.50	4.61	-
3dB Bandwidth	Mhz	4.95	5.00	-
40dB Bandwidth	Mhz	-	6.39	6.50
Passband Ripple	dB	-	0.55	1.00
Group Delay Variation	nsec	-	100	200
Absolute Delay	µsec	-	2.8	-
Ultimate Attenuation	dB	50	55	
Substrate Material	-	LiTaO ₃		
Temperature Coefficient	ppm/°C	-20		

Package Dimension

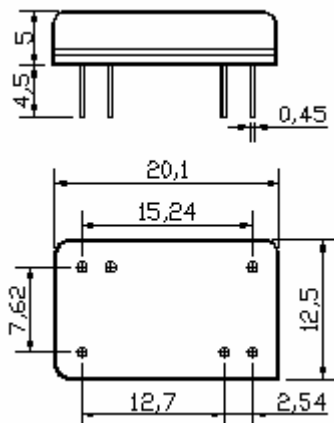

Matching Configuration

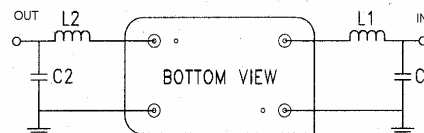

L1=L2=18nH , C1=C2=39pF
Source / Load Impedance = 50Ω
Ambient Temperature = 25°C