

Typical Performance

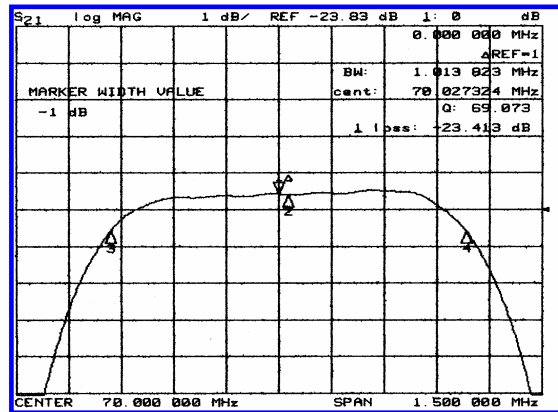
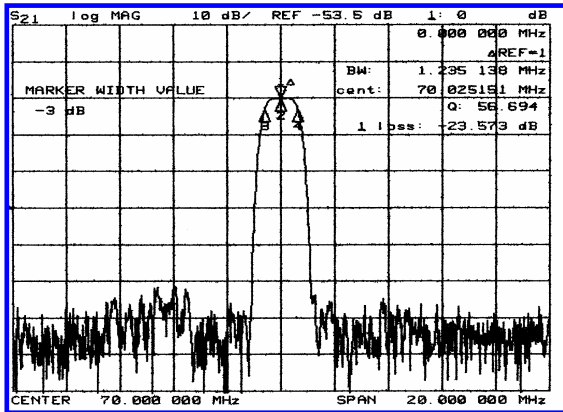

Specification

Parameter	Unit	Min.	Typ.	Max.
Center Frequency	Mhz	69.92	70.00	70.08
Insertion Loss	dB	-	23.50	25.00
1dB Bandwidth	Mhz	0.90	1.00	-
3dB Bandwidth	Mhz	1.20	1.23	-
40dB Bandwidth	Mhz	-	2.09	2.25
Passband Ripple	dB	-	0.35	0.70
Group Delay Variation	nsec	-	100	200
Absolute Delay	µsec	-	3.56	
Ultimate Attenuation	dB	50	55	
Substrate Material	-		Quartz	

Package Dimension

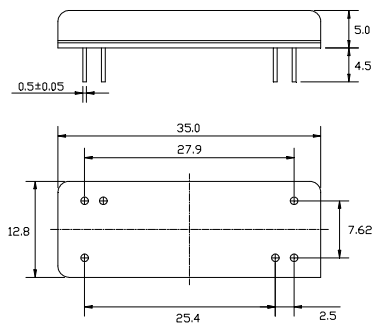

Matching Configuration

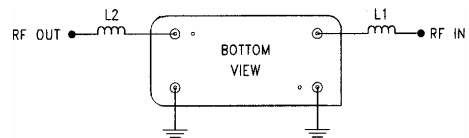

L1=0.18µH , L2=0.18µH
Source / Load Impedance = 50Ω
Ambient Temperature = 25°C