

Typical Performance

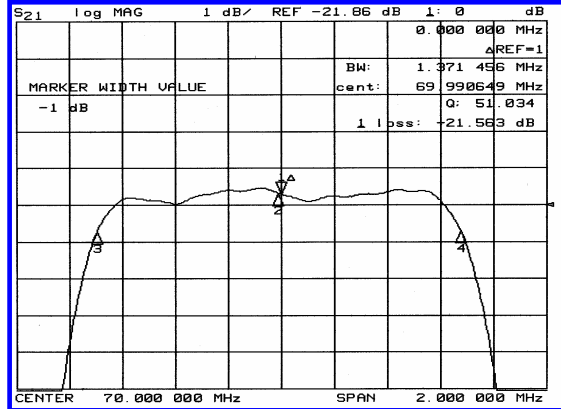
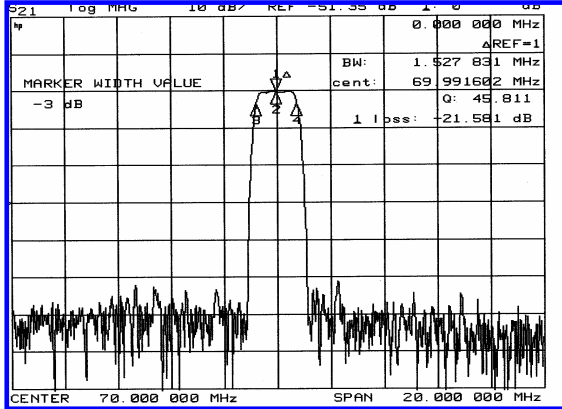

Specification

Parameter	Unit	Min.	Typ.	Max.
Center Frequency	Mhz	69.94	70.00	70.06
Insertion Loss	dB	-	21.50	23.00
1dB Bandwidth	Mhz	1.30	1.37	-
3dB Bandwidth	Mhz	1.45	1.52	-
50dB Bandwidth	Mhz	-	2.23	2.40
Passband Ripple	dB	-	0.55	0.80
Group Delay Variation	nsec	-	150	300
Absolute Delay	µsec	-	3.98	-
Ultimate Attenuation	dB	50	55	-
Substrate Material	-	Quartz		

Package Dimension

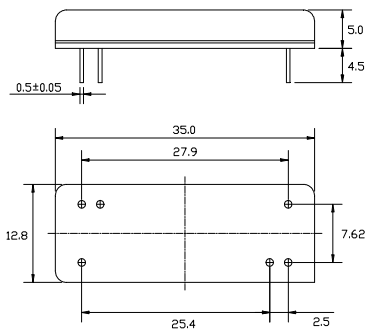

Matching Configuration

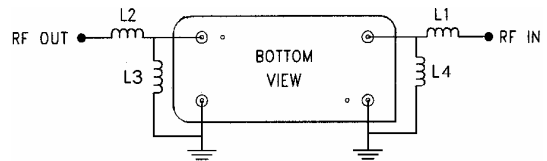

L1=L2=0.18µH, L3=0.47µH, L4=0.33µH  
Source / Load Impedance = 50Ω  
Ambient Temperature = 25°C