

Typical Performance

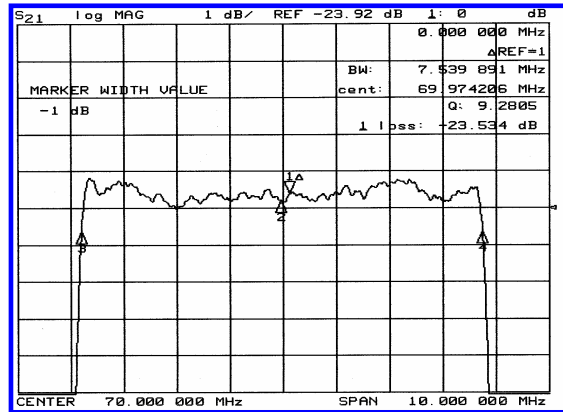
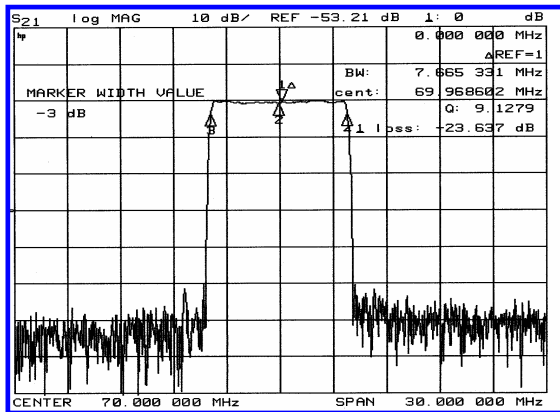

Specification

Parameter	Unit	Min.	Typ.	Max.
Center Frequency	Mhz	69.92	70.00	70.08
Insertion Loss	dB	-	23.50	25.00
1dB Bandwidth	Mhz	7.40	7.54	-
3dB Bandwidth	Mhz	7.50	7.66	-
50dB Bandwidth	Mhz	-	8.27	8.40
Passband Ripple	dB	-	0.85	1.00
Group Delay Variation	nsec	-	50	100
Absolute Delay	µsec	-	4.4	-
Ultimate Attenuation	dB	50	55	-
Substrate Material	-	128-LiNbO ₃		
Temperature Coefficient	ppm/°C	-72		

Package Dimension

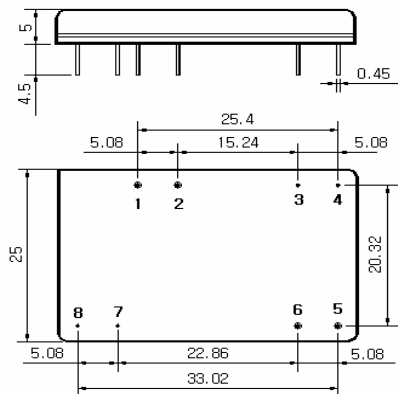

Matching Configuration

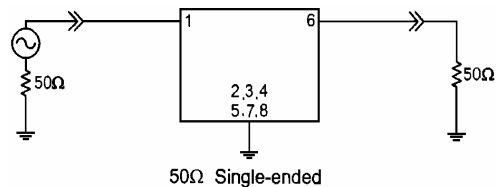

No Matching required
 Source / Load Impedance = 50Ω
 Ambient Temperature = 25°C