

Typical Performance

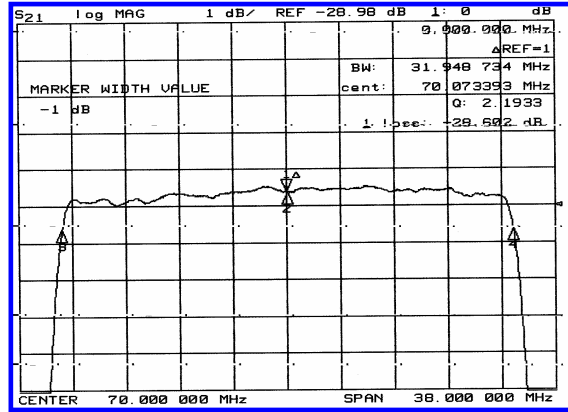
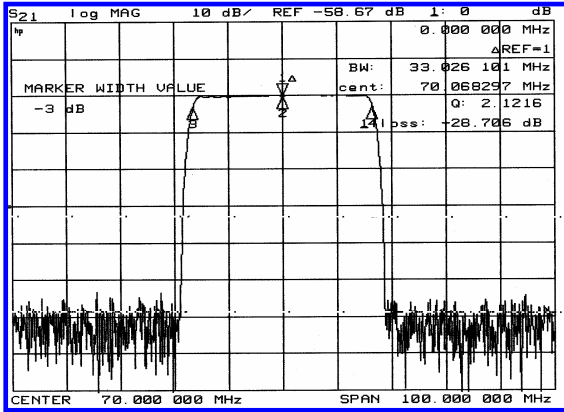

Specification

Parameter	Unit	Min.	Typ.	Max.
Center Frequency	Mhz	69.92	70.00	70.08
Insertion Loss	dB	-	28.50	30.00
1dB Bandwidth	Mhz	31.80	31.95	-
3dB Bandwidth	Mhz	32.85	33.00	-
40dB Bandwidth	Mhz	-	37.20	37.50
Passband Ripple	dB	-	0.65	1.00
Group Delay Variation	nsec	-	20	50
Absolute Delay	µsec	-	1.3	-
Ultimate Attenuation	dB	50	55	
Substrate Material	-	128-LiNbO ₃		
Temperature Coefficient	ppm/°C	-72		

Package Dimension

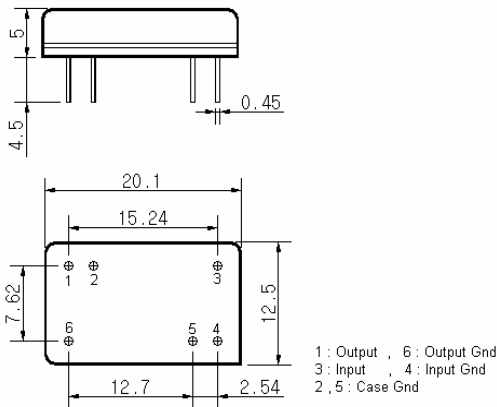

Matching Configuration

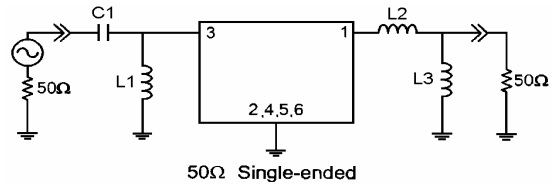

L1= L2=180nH, L3=0.33µH, C1=62pF
Source / Load Impedance = 50Ω
Ambient Temperature = 25°C