

### Typical Performance

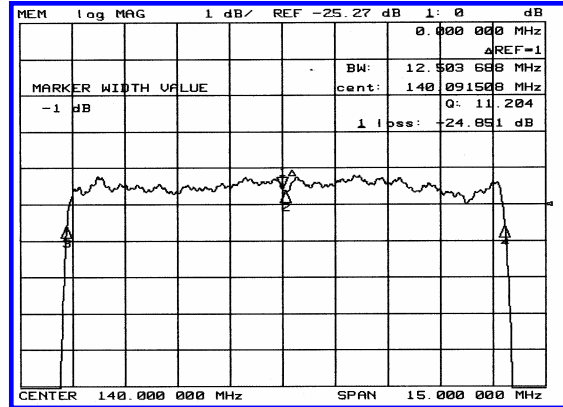
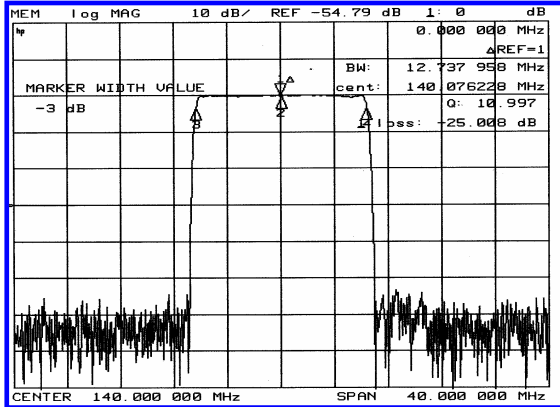

### Specification

Parameter	Unit	Min.	Typ.	Max.
Center Frequency	Mhz	139.85	140.00	140.15
Insertion Loss	dB	-	25.00	26.50
1dB Bandwidth	Mhz	12.30	12.50	-
3dB Bandwidth	Mhz	12.60	12.73	-
40dB Bandwidth	Mhz	-	13.70	14.00
Passband Ripple	dB	-	0.85	1.00
Group Delay Variation	nsec	-	100	200
Absolute Delay	µsec	-	3.1	-
Ultimate Attenuation	dB	50	55	-
Substrate Material	-	128-LiNbO <sub>3</sub>		
Temperature Coefficient	ppm/°C	-72		

### Package Dimension

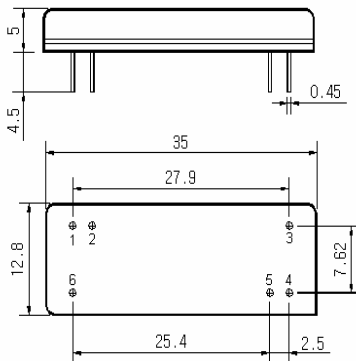

1 : Output , 6 : Output Gnd  
3 : Input , 4 : Input Gnd  
2 , 5 : Case Gnd

### Matching Configuration

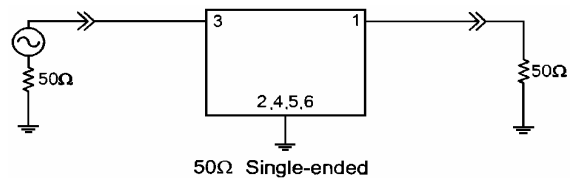

No matching Required  
Source / Load Impedance = 50Ω  
Ambient Temperature = 25°C