

1. Scope.

This specification applied to SV1212-895.5R5V39M

2. Ratings

	ITEM	SYMBOL	RATING	UNIT
1	Supply Voltage	Vcc	5±0.25	V
2	Tuning Voltage	Vt	0.5 ~ 4.5	V
3	Operating Temperature	Top	-40 ~ +85	°C
4	Storage Temperature	Tstg	-50 ~ +100	°C
5	Storage Humidity	Hstg	0 ~ 95%	%

3. Electrical Characteristics

(Over output frequency range, T_A -40 to +85°C, Vcc=5.0V, Output load 50Ω, Unless otherwise stated)

ITEM	SPEC.			UNIT	Test conditions
	Min	Typ	Max		
Supply Voltage		5		V	DC Voltage
Frequency			915	MHz	Vcc = 5.0V, Vt = 0.5V
	876				Vcc = 5.0V, Vt = 4.5V
Current		24	30	mA	Vcc = 5.0V, Vt = 2.5V
Output Level	-2	0	2	dBm	Vcc = 5.0V, Vt = 0.5V ~ 4.5V
Phase Noise (C/N)		89	85	dBc/Hz	1kHz offset, Vcc=5.0V, Vt =2.5V
		114	110	dBc/Hz	10kHz offset, Vcc=5.0V, Vt =2.5V
		134	130	dBc/Hz	100kHz offset, Vcc=5.0V, Vt =2.5V
		154	150	dBc/Hz	1MHz offset, Vcc=5.0V, Vt =2.5V
		164	155	dBc/Hz	100MHz offset, Vcc=5.0V, Vt =2.5V
2 nd Harmonic		-23	-12	dBc	Vcc = 5.0V, Vt = 2.5V
Tuning Sensitivity	10	16		MHz/V	Vt = 0.5V ~ 4.5V
Pulling		< 2		MHz	Vcc = 5.0V, Vt = 2.5V VSWR = 1.5 : 1 All phase
Pushing		< 1.5		MHz	Vcc = 5.0V ±0.25V, Vt= 2.5V
Input Capacitance		47		pF	

Testing temperature at 25±5°C

4. Measurement Circuit

Test Equipment : Agilent E5052A or 4352B

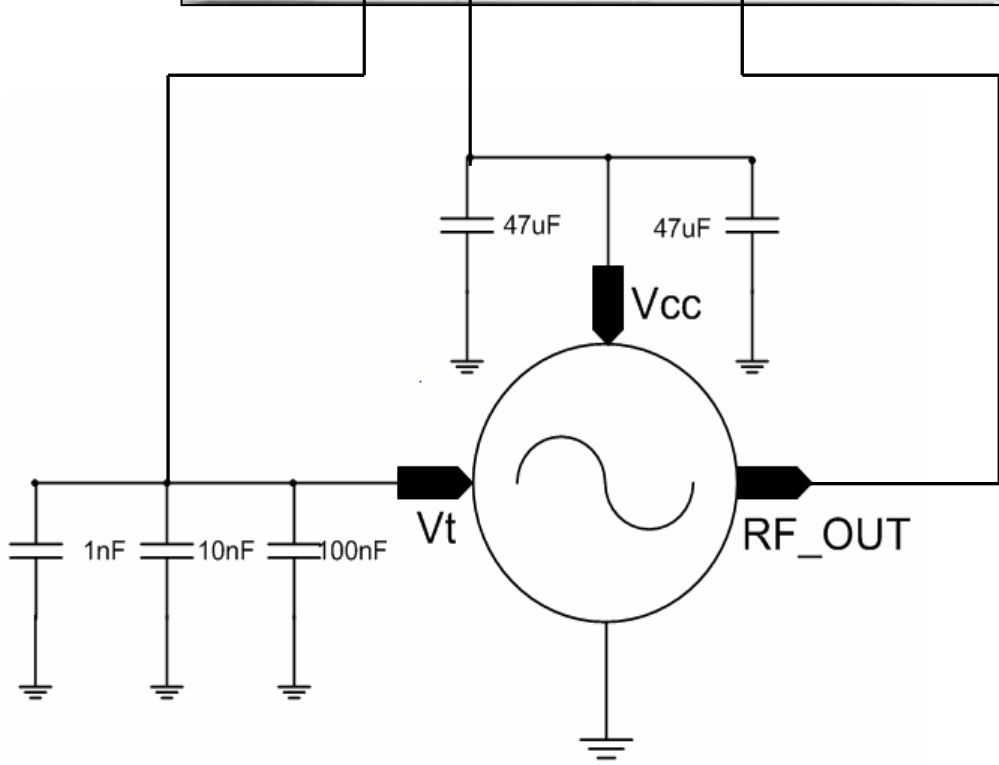
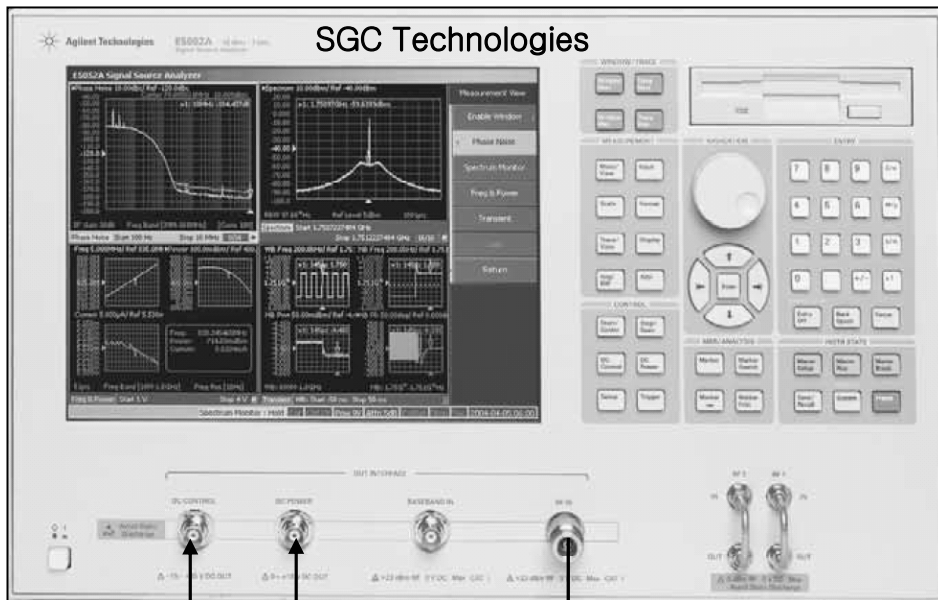

5. Recommendable Reflow Soldering Profile (Pb - Free)

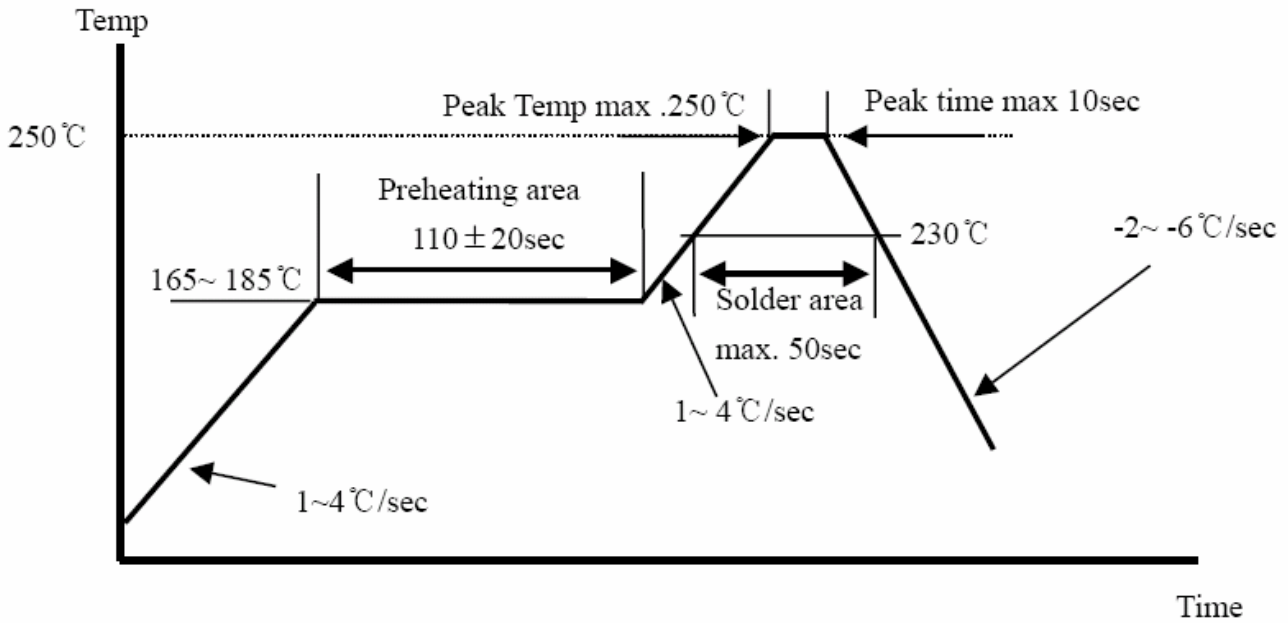

6. Recommendable Reflow Soldering Profile (Sn : Pb = 63:37))

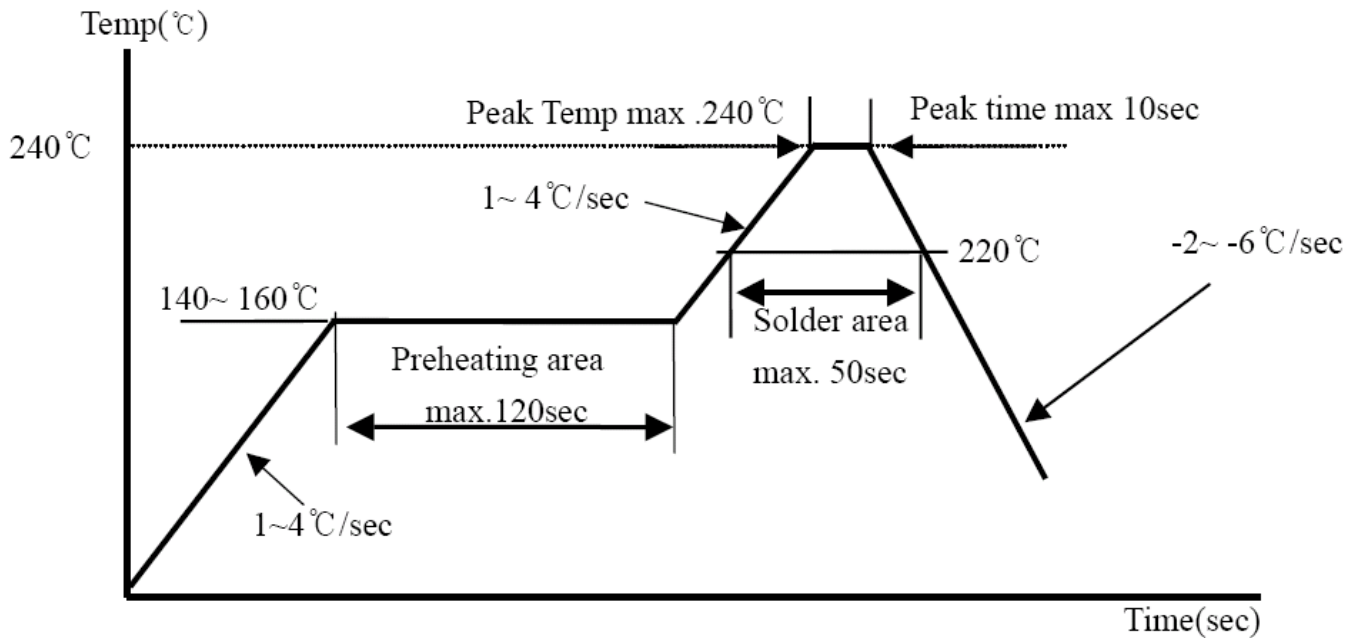

7. Environmental Requirement

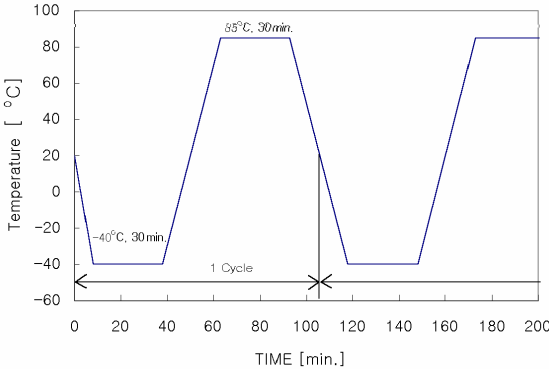
No	ITEM	Condition and Method	Evaluation
1	High Temperature Test	Temp. : +85°C ± 2°C Time : 96hrs ± 2hrs When measured after 2 to 24 hours in normal condition	It shall be satisfied electrical requirement, and not be mechanical damage.
2	Low Temperature Test	Temp. : -40°C ± 2°C Time : 96hrs ± 2hrs When measured after 2 to 24 hours in normal condition	
3	High Temperature & High Humidity	Temp. : +60°C ± 2°C Humi. : 90~95%RH Time : 72hrs ± 2hrs When measured after 2 to 24 hours in normal condition	
4	Temperature Cycle	 <p>-40°C 30min., +85°C 30min., 5 Cycle When measured after 2 to 24 hours in normal condition</p>	
5	Vibration Test	Freq. : 10~30Hz, Amplitude : 1.52mm Freq. : 30~60Hz, 6G Cycle : 20 min. / Cycle Position : Three perpendicular planes.	
6	Shock Test	Height : 75cm Times : 3 Method : Dropped onto wood surface	

8. Mechanical Characteristics

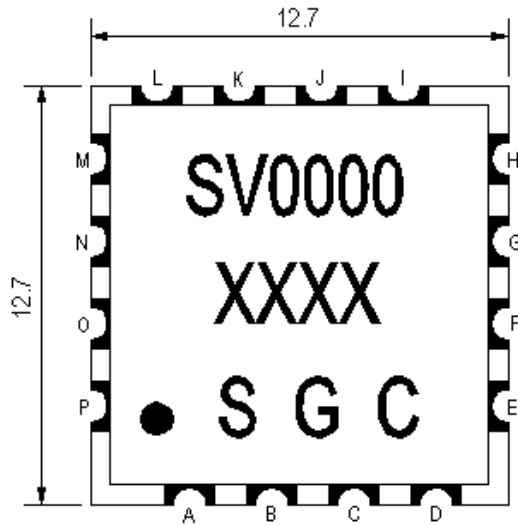

TITLE OF TERMINAL

A,C,D,E,F,G,H,I,K,L,M,O,P : Ground

N : Power Supply

J : Output Power

B : Control Votage

* Unit : mm

